

DEPARTMENT OF THE ARMY TECHNICAL MANUAL

FIELD AND DEPOT
MAINTENANCE MANUAL

COMPRESSOR, RECIPROCATING, POWER-DRIVEN
FLAMETHROWER, 3 ½ CFM, AN-M4
(END ITEM CODE 317)

This reprint includes all changes in effect
at the time of publication-Change 2.

HEADQUARTERS, DEPARTMENT OF THE ARMY
AUGUST 1963

Change
No. 2 }
}

HEADQUARTERS
DEPARTMENT OF THE ARMY
Washington, D.C., 17 March 1971

**DS, GS, and Depot Maintenance Manual
COMPRESSOR UNIT, RECIPROCATING;
POWER-DRIVEN, FLAMETHROWER,
3 ½ CFM, AN-M4
(FSN 1040-592-8560)**

TM 3-1040-210-35, 5 August 1963, is changed as follows:

Title is changed as shown above.
So much of this manual as reads -
"first echelon" is changed to read "operator or crew"
"second echelon" is changed to read "organizational"
"third echelon" is changed to read "direct support"
"fourth echelon" is changed to read "general support"
"fifth echelon" is changed to read "depot maintenance"
"field maintenance (third echelon)" is changed to read "direct support maintenance"
"field maintenance (fourth echelon)" is changed to read "general support maintenance"
All references to the "echelon of maintenance" are changed to read "category of maintenance."
Page 1. Section VIII, Chapter 3, is rescinded.
Paragraphs "55, 56," are changed to read "53, 54."
Page 2. Paragraph 3b is superseded as follows:
b. The reporting of errors, omissions, and recommendations for improving this manual by the

individual user is encouraged. Reports should be submitted on DA Form 2028 (Recommended Changes to Publications) and forwarded direct to Commanding Officer, Edgewood Arsenal, ATTN: SMUEA-TSE-TP, Edgewood Arsenal, Md. 21010. Paragraph 4.1 is added after paragraph 4.

4-1 Special Equipment

General support maintenance personnel are responsible for surveillance and testing of all AN-M4 compressor units in accordance with TB 742- 93-1.
Page 13, paragraph 23. Add the following:
The water separator (air receiver) will be tested and recorded, in accordance with TB 742-93-1, every 24 months or at any time a malfunction or erratic operation occurs.
Page 35. Section VIII is rescinded.
Page 37. Paragraphs 55 and 56 are changed to read 53 and 54.
Page 38, appendix I, REFERENCES. Add the following:
TB 742-93-1 Inspection and Test of Air and Other Gas Compressors

*This change supersedes C1, 20 April 1966

By Order of the Secretary of the Army:

W.C. WESTMORELAND,
General, United States Army,
Chief of Staff

Official:

KENNETH G. WICKHAM,
Major General, United States Army,
The Adjutant General.

Distribution:

Active Army:

CNGB (1)	PG (5)
USAMB (2)	Ft Knox FLDMS (10)
USAMC (5)	Units org under fol TOE:-2 ea.
USAMUCOM (5)	3-7
USACDC (2)	3-32
USACDC Agcy (2)	3a36
USACDCEC (10)	3-500
OS Maj. Comd (5)	29-1
CONARC(25)	29-11
ARADCOM (5)	29-15
ARADCOM Rgn (5)	29-16
Armies (5)	29-17
Corps (3)	29-21
Div (3)	2925
Instl (2) except	29-26
USAECFB (4)	29-27
USAFACFS (4)	29-35
USMA (10)	297
Svc Colleges (10)	29-51
Br Svc Sch (10) except	29-55
USACMLCS (50)	2956
USATC (1)	29-57
USAPC (2)	275
USAMMCS (2)	29-79
USAIC (2)	29-99
Gen Dep(5)	29-105
Dep (5)	29-109
Army Dep (5)	29-134
POE (1)	29-136
EAMTMTS(1)	29-138
WAUTMTS (1)	29-202
MOTBA (1)	29-2D6
MOTBY (1)	29-207
MOTKI (1)	29-208
MOTSU (1)	29-247
USAAPSA (25)	29.427
Arsenals (3) except	29-500
Edgewood (75)	29-600
USAARMC (2)	29-610

ARNG: State AG (3); units org under TOE 7-2, 17-2(1).

USAR: Same as active Army except allowance is one (1) copy each.

For explanation of abbreviations used, see AR 310-50.

**FIELD AND DEPOT MAINTENANCE MANUAL
COMPRESSOR, RECIPROCATING, POWER DRIVEN
FLAME THROWER, 3½ CFM, AN M4
(End Item Code 317)**

			Paragraph	Page
CHAPTER	1.	INTRODUCTION		
Section	I.	General	1, 4	2
	II.	Description and data	5, 6	2
CHAPTER	2.	FIELD MAINTENANCE INSTRUCTIONS-THIRD ECHELON		
Section	I.	General	7, 9	5
	II.	Water separator group	10, 12	5
	III.	Compressor group	13, 14	6
	IV.	Engine group	15, 16	9
	V.	Frame-fuel tank group	17, 18	10
CHAPTER	3.	FIELD MAINTENANCE INSTRUCTIONS-FOURTH ECHELON		
Section	I.	General	19, 20	12
	II.	Water separator group	21, 23	12
	III.	Fan group	24, 25	15
	IV.	Intercooler and aftercooler section	26, 27	16
	V.	Compressor group	28, 48	17
	VI.	Engine group	49, 50	33
	VII.	Frame-fuel tank group	51, 52	34
	VIII.	Periodic surveillance test	53, 54	35
CHAPTER	4.	DEPOT MAINTENANCE INSTRUCTIONS-FIFTH ECHELON	55, 56	37
APPENDIX I		REFERENCES		38

CHAPTER 1
INTRODUCTION
Section I. GENERAL

1. Scope

This manual is published for the information and guidance of personnel responsible for maintenance, repair and overhaul of the AN-M4 31.) CFM flamethrower power-driven reciprocating compressor. The publication contains information of maintenance authorized to be performed by field and depot maintenance personnel. It is intended to be used with TM 3-1040-210-12. TM 5-2805-206-14 contains maintenance information on the gasoline engine.

Note. These instructions apply only to AN-M4 compressors manufactured by Walter Kidde and Co., Inc., under Contract DA 30-070-CML-1662.

2. Appendix

The appendix contains a list of current references.

3. Record and Report Forms

a. Maintenance Forms. The forms listed below will be used to report and record maintenance actions in compliance with TM 38-750.

(1) DA Form 2404 (Equipment Inspection and Maintenance Worksheet).

(2) DA Form 2407 (Maintenance Request).
(3) DA Form 2408-11 (Accumulative Repair Cost Record).

(4) DA Form 2409 (Equipment Maintenance Log (Consolidated)).

b. DA Form 2028 (Recommended Changes to Technical Manuals, Parts Lists, or Supply Manuals). Use this form to forward comments on errors or omissions in this manual to Commanding General, U.S. Army Edgewood Arsenal, ATTN: SMUEA-ELS-EM-P, Edgewood, Md.

c. DD Form 6 (Report of Damaged or Improper Shipment). Use this form to report damages sustained in shipment or caused by improper shipment.

4. Allocation of Maintenance

Refer to the maintenance allocation chart in TM 3-1040-210-12 for maintenance authorized at each echelon of maintenance. Be sure that a part is in stock before attempting to replace it.

Section II. DESCRIPTION AND DATA

5. Description

The AN-M4 compressor assembly delivers 31/2 CFM of high pressure air at 2000 psi used to charge pressure tanks of portable flame-throwers and riot control agent dispensers. The unit is completely self-contained and consists of a three-stage radial compressor, a gasoline engine, and various accessory components necessary for operation, transportation and protection of the unit. The compressor consists of seven groups: a canvas group, water separator group, fan group, cooler group, compressor group, engine group, and a frame-fuel tank

group (fig. 1). A complete description of each group is contained in the section in this manual covering the maintenance for each group.

For purposes of orientation, the ends of the air compressor assembly will be called "pulley end" or "rear" and the "fan end" or "front." The term "left" or "right" as used will be referenced to the unit as viewed from the "fan end" or "front" while looking toward the "pulley end."

6. Tabulated Data

a. General.

AGO 5548A

Number of cylinders	1
Bore	24 in.
Stroke	2 in.
Compression ratio	:1
Horsepower (at 3,600 r.p.m.)	1%
(6) Frame.	
Length21%in.
Height18%in.
Width16% in.

b Recommended Wrench Torques and Tolerances.

<i>Component</i>	<i>Torque and Tolerance (pound-feet)</i>
Overall unit:	
Screw, adapter shaft to engine.....	20
Bolt, compressor adapter	7 to 8
engine.	
Nut, fan.....	17
Nut, flared tube.....	3 to 5
Screw, fan guard bracket	4 to 5
Screw, fan guard	3 to 4
1st stage intercooler nuts	3 to 5
Aftercooler nuts	3 to 5
2nd stage intercooler nuts.....	to 5
Nut, large clamp	4 to 5
Nut, short clamp	4 to 5
Bolts, compressor flange to.....	8 to 9
gasoline engine.	
Bolts, clip angles to gasoline	5 to 7
engine.	
Bolts, gasoline engine to	5 to 7
lower frame.	
Bolts, fuel tank assembly to	5 to 7
lower frame.	
Water separator:	
Relief valve fitting	2
Valve, relief.....	3 to 5
Valve, Cap.....	17
Nut, elbow	11 to 13
2nd stage relief valve:	
Retainer, seat.....	
Compressor group:	
Stage screws:	
1st stage head	30 to 35
	pound inches

<i>Component</i>	<i>Torque and Tolerance (pound-feet)</i>
1 st stage cap	17 to 22
	pound inches
1 st stage seat (max.).....	100
	pound inches
2d stage head.....	60 to 65
	pound inches
3d stage head.....	60 to 65
	pound inches
Bolts, crankcase to adapter	5 to 7
Oil pump:	
Screws, attachment.....	2 to 3
Retainer, pump spring	3 to 5
Retainer, strainer.....	3 to 5
Plug, piston pin port	17 to 21
Plug, sump drain port.....	33 to 42
Plug, lower crankcase.....	4 to 5
Screw, spring attachment	to 6
Screw, 1st stage head valving	8
(max.).	

c Fits and Tolerances Listed below are the manufacturer's assembly clearances and tolerances.

<i>Description</i>	<i>Clearance and Tolerance (in)</i>
<i>Head clearance, compressor group:</i>	
1 st stage.....	.036 to .040
2d stage.....	.028 to .032
3d stage.....	.028 to .032
<i>Diametral clearance, compressor group:</i>	
Plunger to cylinder, 3d stage.....	.00015 to .00025
Plunger to cylinder, 2d stage.....	.0018 to .00029
Piston to cylinder, 1st stage.....	.0023 to .0036
Piston pin to piston, 1st stage0000 to .0005
Piston pin, 1st stage to0006 to .0012
keystone.	
Keystone to crankshaft.....	.0007 to .0012
Crankshaft to crankcase0010 to .0025
bushing.	
Crankshaft to gerotor0005 to .0015
Crankshaft to backup ring.....	.0050 to .0065
<i>Side clearance, compressor group:</i>	
Gerotor.....	.001 to .002
Piston pin, 1st stage.....	.002 max.
(end play).	

CHAPTER 2

FIELD MAINTENANCE INSTRUCTIONS-THIRD ECHELON

Section I. GENERAL

7. Special Tools

No special tools are required for third echelon maintenance of the power driven, reciprocating air compressor.

8. Special Equipment

No special equipment is required for the third echelon maintenance of the air compressor.

9. Painting

a. General. Field maintenance personnel are authorized to retouch the paint on the air compressor assembly when the paint is damaged or removed during repair. When necessary, thor

oughly clean the surface and repaint. See TM 9-213 for general instructions for cleaning and methods of painting. Surfaces to be protected with paint and primers are indicated in the maintenance instructions.

b. Paints to Be Used.

- (1) Primer. Prime all worn, scratched or chipped surfaces of steel components only, with one coat of corrosion resisting synthetic primer.
- (2) Exterior enamel. Repaint all worn, scratched or chipped painted surfaces with two coats of green synthetic lustreless enamel.

Section II. WATER SEPARATOR GROUP

10. Description

The water separator group (fig. 2) is located on the frame assembly of the air compressor and is held in place by a clamp. An inlet elbow, an outlet plug, and a needle valve are attached to the water separator. The needle valve is used to drain the collected moisture from the water separator. The water separator group consists of the water separator, a relief valve, and the needle valve.

11. Function

The water separator separates the entrained moisture from the high pressure compressed air. In addition, the water separator permits drainage of collected moisture and dampens the pulsation of the air delivered to the tank or cylinder being charged.

12. Maintenance

Third echelon maintenance personnel are authorized to replace the needle valve, clamp, preformed packings, packing retainer, tube fitting

locknut, outlet valve, relief- valve, and hardware, as required.

a. Removal.

- (1) Open the needle valve (5, fig. 2) and drain the water separator (1).
- (2) Loosen the inlet connection on the aftercooler (6, fig. 9), from the elbow (12, fig. 3).
- (3) Unscrew the fitting (6, fig. 2) from the needle valve (5).
- (4) Loosen the nut (4) and remove the needle valve from the water separator.
- (5) Remove the washer (3) and nut (4) from the needle valve.
- (6) Open the clamp (2) and remove the water separator and clamp from the frame.

b. Disassembly (fig. 3).

- (1) Unscrew the relief valve (2) from the water separator cap (6). Remove the preformed packing (3) from the relief valve.

AGO 5548A.

- (2) Unscrew the outlet plug (4) from the water separator cap (6). Remove the preformed packing (5) from the outlet plug.
 - (3) Loosen the lock nut (13) and unscrew the elbow (12) from the water separator cap (6). Remove the preformed packing (15), packing retainer (14) and lock nut from the elbow.
 - (4) Use a strap wrench and unscrew the shell (11) from the water separator cap (6). Remove the preformed packing (10) from the water separator cap.
 - (5) Unscrew the baffle assembly (1) from the water separator cap (6). Remove the lockwasher (9) from the baffle assembly.
- c. *Cleaning and Inspection.*
- (1) Clean all metal parts in dry-cleaning solvent.
 - (2) Inspect all parts for distortion, wear, cracks, or other damage. Replace if defective.
 - (3) Replace all preformed packings.
- d. *Lubrication.*
- (1) Lubricate all replacement preformed packings with OE-0 oil.
 - (2) Lubricate all threaded surfaces with OE30 oil.
- e. *Assembly (fig. 3).*
- (1) Position the lockwasher (9) over the threaded area of the baffle assembly (1) and screw the baffle assembly securely into the cap (6).
 - (2) Position the preformed packing (10) into the cap (6).
 - (3) Position the shell (11) in a suitable holding fixture or vise so that half of the shell extends above the jaws of the vise or fixture and the inlet port is facing front; clamp securely. Assemble the baffle and cap assembly into the shell and torque to 17 pound-feet.
 - (4) Assemble the locknut (13) as far back as possible onto the large threaded end of the elbow (12) with the center bore of the nut facing out. Position

- the packing retainer ,(14) and the preformed packing (15) into the center bore of the locknut.
- (5) Screw the elbow (12), nut-end in, into the inlet port of the cap (6), turning the nut with the elbow, until the preformed packing (15) contacts the cap. With the elbow in this position, hold the locknut (13) with a suitable wrench to prevent running and turn the elbow in one and one-half turns. Position the elbow by turning no more than one more additional turn.
 - (6) Hold the elbow (12) in the desired position and torque the locknut between 11 to 13 pound-feet.
 - (7) Perform the test indicated in g below.
 - (8) Assemble the preformed packing (3) to the relief valve (2).
 - (9) Assemble the relief valve (2) to the relief valve port in the cap (6) and torque the relief valve between 3 to 5 pound-feet.
 - (10) Position the preformed packing (5) on the outlet plug (4).
 - (11) Assemble the outlet plug (4) to the outlet port in the cap (6).
- f. *Installation.*
- (1) Position the clamp (2, fig. 2) in the lower frame (9, fig. 21).
 - (2) Position the water separator assembly (1, fig. 2) in the lower frame and secure with the clamp (2, fig. 2).
 - (3) Assemble the washer (3), nut (4), needle valve (5) and fitting (6) to the drain port of the water separator assembly.
- g. *Test.*
- (1) Operate the compressor, as required during normal operation, bringing the water separation to operating pressure.
 - (2) Apply soap solution to all joints and check for leakage. No leakage is per-

Section III. COMPRESSOR GRUUP

13. Description and Function

The compressor group is a three-stage, re-

ciprocating, air compressor whose purpose is to supply high pressure compressed air. In

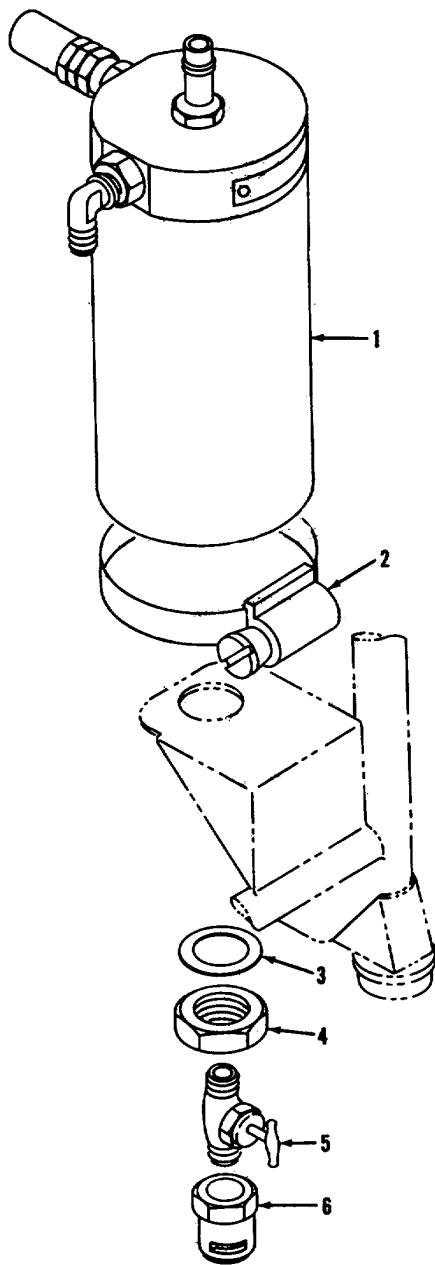

- | | | | |
|---|-----------------|---|--------------|
| 1 | Water separator | 4 | Nut |
| 2 | Clamp | 5 | Needle valve |
| 3 | Washer | 6 | Fitting |

Figure 2. Water separator group, exploded view.

In addition to the three pressure stages, the compressor group includes a crankcase section. The crankcase section consists of the crankshaft, keystone, gerotor, bearings, and a crank-

case. The crankcase is a single casting comprising the 1st stage cylinder, the 2d stage cylinder, the oil sump as well as the housing for the rotating parts. Located in the oil sump portion of the crankcase are the drain plug, rod-cap and tube assembly. The tube assembly serves to siphon and filter the oil from the oil sump to the gerotor which pumps the oil to the other portions of the compressor group. The rod-cap is located at the top of the oil sump and is used to determine the oil level within the oil sump. The drain plug is located at the bottom of the oil sump and is used to drain the oil sump and to provide an access to the tube assembly.

14. Maintenance

Third echelon maintenance personnel are authorized to replace the drain plug, preformed packing, rod-cap, spring tension washer, tube assembly and any attaching hardware.

a. *Removal.* Removal of the compressor group is not required for replacement of components at the third echelon.

b. *Disassembly (fig. 4)*

- (1) Unscrew the drain plug (7) from the crankcase and remove the preformed packing (6).
- (2) Rotate the rod-cap (1) and remove it from the crankcase. Remove the preformed packing (2).
- (3) Disassemble the two screws (3) and remove the spring tension washer (4) from the crankcase.
- (4) Unscrew the tube assembly (5), using a suitable size screwdriver, and remove it from the interior of the oil sump of the crankcase.

c. *Cleaning and Inspection (fig. 4).*

- (1) Clean all metallic parts with dry-cleaning solvent.
- (2) Blow out the tube assembly (5) through both orifices using compressed air.
- (3) Inspect all parts for distortion, cracks, defective threads or other damage. Replace if defective.
- (4) Replace the preformed packings (2 and 6) and the spring tension washer (4).

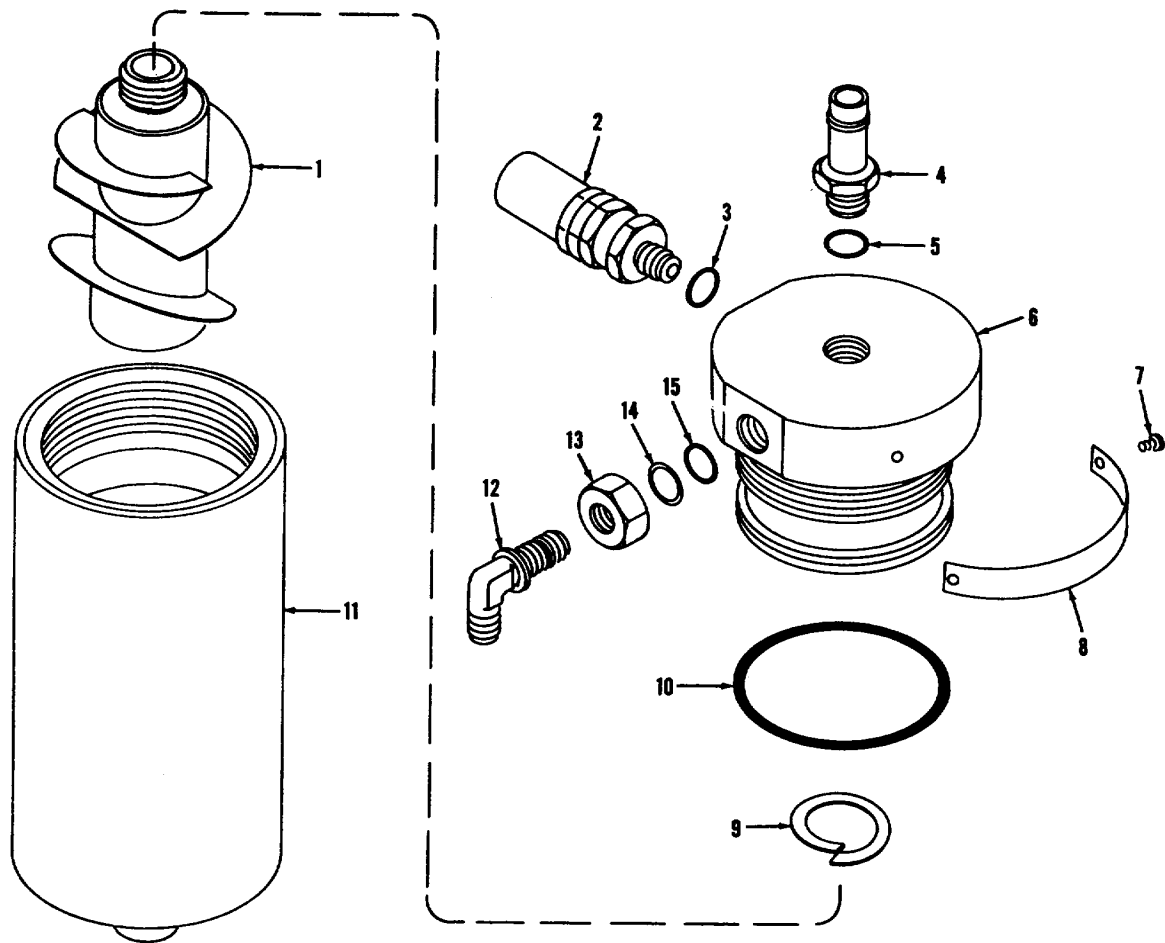

- | | | |
|---------------------|----------------------|----------------------|
| 1 Baffle assembly | 6 Cap | 11 Shell |
| 2 Relief valve | 7 Screw | 12 Elbow |
| 3 Preformed packing | 8 Nameplate | 13 Locknut |
| 4 Outlet plug | 9 Lockwasher | 14 Packing retainer |
| 5 Preformed packing | 10 Preformed packing | 15 Preformed packing |

Figure 3. Water separated, exploded view

d. Lubrication.

- (1) Apply oil (OE-30) to the preformed packings.
- (2) Apply oil (OE-30) to all threaded fittings.

e. Assembly (fig. 4).

- (1) Screw the tube assembly (5) into the orifice in the interior of the oil sump of the crankcase.
- (2) Position the preformed packing (6) on the drain plug (7) and screw the drain plug into the drain port at the

bottom of the oil sump of the crank-case.

(3) Position the spring tension washer (4) on the oil fill port of the crankcase and secure with the two screws (3).

(4) Position the preformed packing (2) on the rod-cap (1); position the rod-cap in the oil-fill port of the crank-case and secure by rotation to engage the spring catch of the spring tension washer to the protruding pins on the rod-cap.

AGO 5548A

Section IV. ENGINE GROUP

15. Description and Function

The engine group is a one cylinder, four-stroke, internal combustion, gasoline engine used to drive the air compressor group. A fuel tank, is attached to the frame. The gasoline flows from the tank through a connector and filter to a shutoff cock located at the glass filter bowl. From the shut-off cock, the gasoline flows through the filter bowl to the fuel metering system in the gasoline engine.

16. Maintenance

Third echelon maintenance personnel are authorized to replace the fuel tank, preformed packings, connector and filter, shutoff cock,

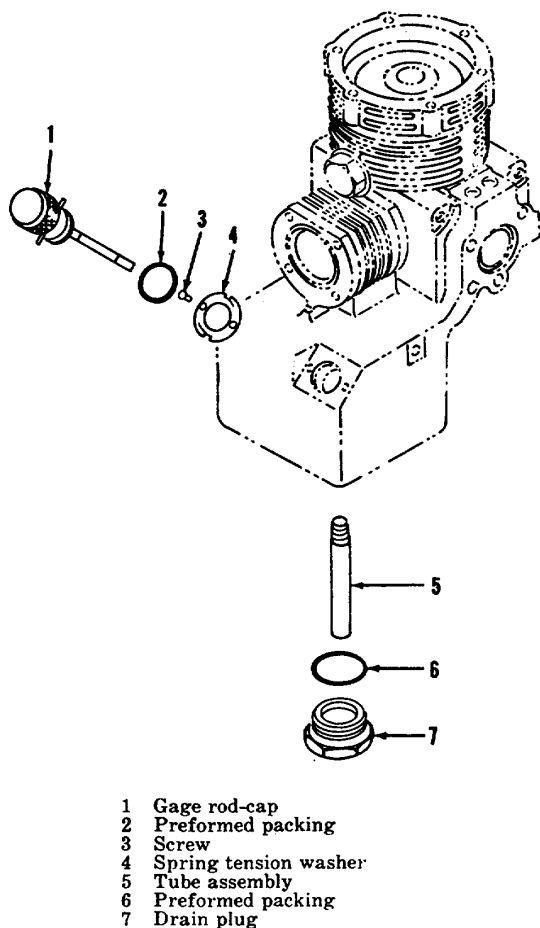
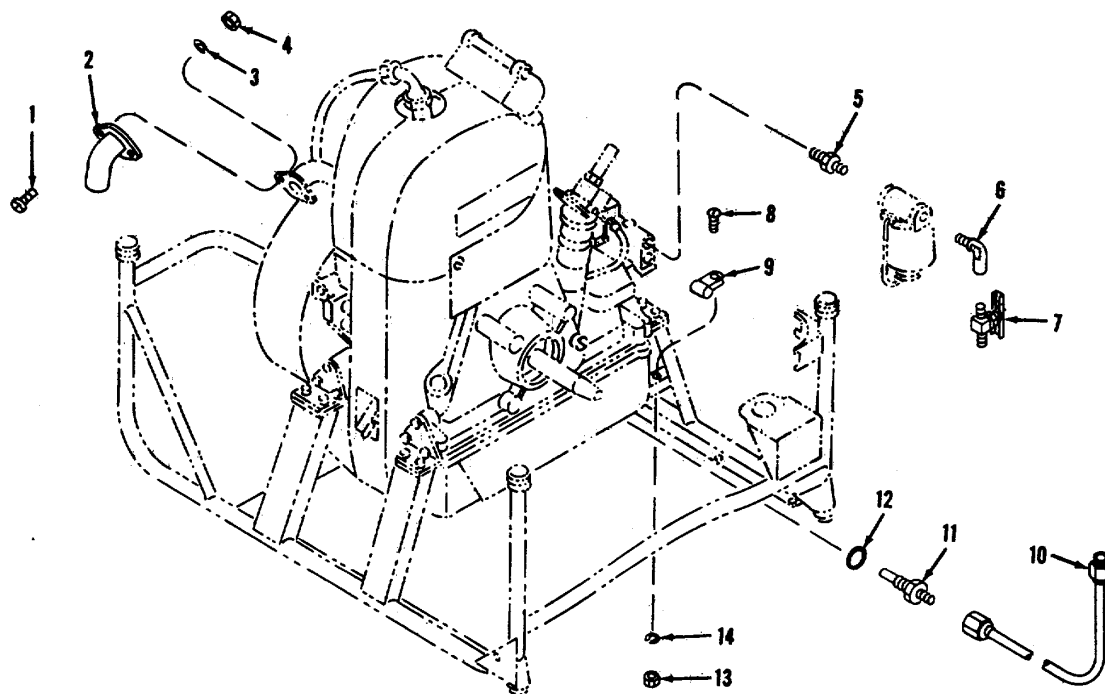

Figure 4. Oil sump accessories, exploded view.

elbow, union, exhaust pipe, and the attaching hardware.

- a. *Disassembly (fig. 5).*
 - (1) Disconnect and remove the tube assembly (10) from the connector and filter (11) and the shutoff cock (7) after removing the nut (13), washer (14), screw (8), and tube clamp (9).
 - (2) Unscrew the connector and filter (11) from the fuel tank.
 - (3) Remove the preformed packing (12) from the connector and filter (11).
 - (4) Unscrew the elbow (6) and shutoff cock (7) from the filter bowl; unscrew the elbow from the shutoff cock.
 - (5) Unscrew the filter bowl from the union (5).
 - (6) Unscrew the union (5) from the gasoline engine.
 - (7) Disassemble the nut (4), washer (3), and screw (1) and remove the exhaust pipe (2) from the gasoline engine.
- b. *Cleaning and Inspection (fig. 5).*
 - (1) Clean all metallic parts with dry-cleaning solvent.
 - (2) Air dry and clean the connector and filter (11) with compressed air.
 - (3) Inspect all components for damaged threads, cracks, distortion or other defects.
 - (4) Replace preformed packing (12).
- c. *Lubrication.*
 - (1) Apply antiseize compound per JAN-A-669 to all threaded fittings.
 - (2) Apply oil per MIL-L-2104, OE-30 to preformed packings.
- d. *Assembly (fig. 5).*
 - (1) Position the exhaust pipe (2) on the exhaust port of the gasoline engine and secure with the screw (1), washer (3), and nut (4).
 - (2) Screw the union (5) into the carburetor inlet port of the gasoline engine.
 - (3) Assemble the filter bowl of the gasoline engine onto the union (5).
 - (4) Assemble the elbow (6) of the shutoff cock (7).
 - (5) Screw the elbow (6) to the inlet port of the filter bowl.
 - (6) Position the preformed packing (12) on the connector and filter (11).
 - (7) Screw the connector and filter (11)



- 1 Screw
- 2 Exhaust pipe
- 3 Washer
- 4 Nut
- 5 Union
- 6 Elbow
- 7 Shutoff cock

- 8 Screw
- 9 Tube clamp
- 10 Tube assembly
- 11 Connector and filter
- 12 Preformed packing
- 13 Nut
- 14 Washer

Figure 5. Gasoline engine accessories, exploded view.

onto the outlet port of the fuel tank. The filter of the connector and filter should be inside the fuel tank.

- (8) Assemble the tube assembly (10) to the connector and filter (11) and to

the shutoff cock (7); position the tube clamp (9) on the tube assembly and secure to the frame assembly with the screw (8), washer (14), and nut(13).

Section V. FUEL TANK

17. Description and Function

The fuel tank consists of a tank, an inlet port, a drain port, and a fuel outlet port. A cap is attached to the inlet port to prevent foreign matter from entering the tank and to retain the contents of the tank during transportation of the air compressor. The cap is held to the fuel tank by a chain and two hooks to prevent loss of the cap. A drain plug is located at the bottom of the tank and is used to drain the fuel from the tank.

18. Maintenance

Third echelon maintenance personnel are authorized to replace the drain plug, chain hooks, chain, cap assembly, and preformed packing on the tank.

a. Disassembly (fig. 6).

- (1) Unscrew the drain plug (6) from the bottom of the tank.
- (2) Remove the preformed packing (5) from the drain plug.

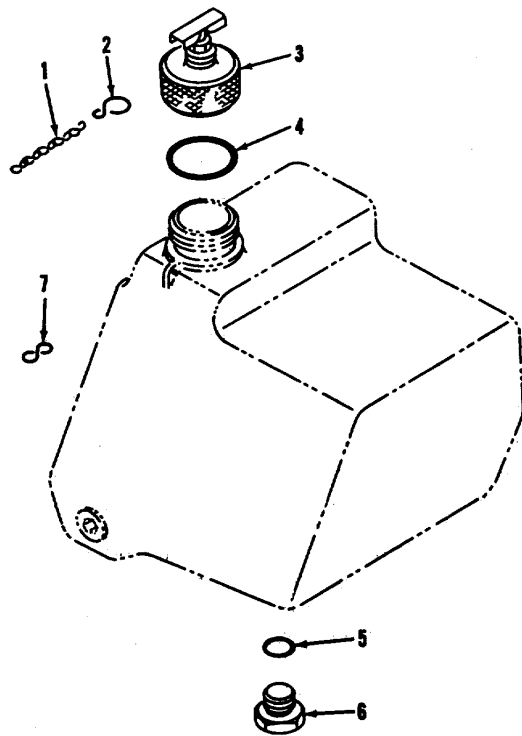

- 1 Chain
- 2 Hook
- 3 Cap
- 4 Preformed packing
- 5 Preformed packing
- 6 Plug
- 7 Hook

Figure 6. Fuel tank accessories, exploded view.

- (3) Straighten the hooks (2 and 7) enough to permit removal of the hooks from the cap (3), chain (1) and tank; remove chain.
- (4) Unscrew the cap (3) from the tank.
- (5) Remove the preformed packing (4) from the cap (3).
- b. *Cleaning and Inspection (fig. 6).*
 - (1) Clean metallic parts with dry-cleaning solvent.
 - (2) Inspect components for damaged threads or other defects.
 - (3) Replace preformed packings (4 and 5).
- c. *Lubrication (fig. 6).* Apply oil per MIL-L2104, OE-30 to the preformed packings (4 and 5).
- d. *Assembly (fig. 6).*
 - (1) Position the preformed packing (4) on the cap.
 - (2) Screw the cap (3) on the inlet port of the tank.
 - (3) Attach the hooks (2 and 7) to the chain (1) bending the ends of the hooks to prevent loss of chain (1).
 - (4) Attach hook (2) to the cap (3) and hook (7) to the tank. Bend the hooks to secure the chain (1) to the cap and the tank.
 - (5) Position preformed packing (5) on drain plug (6).
 - (6) Screw the drain plug (6) into the drain port on the tank.

CHAPTER 3
FIELD MAINTENANCE INSTRUCTIONS-FOURTH ECHELON

Section I. GENERAL

19. Special Tools

No special tools are required. However, the following common tools are required for the disassembly and assembly of the compressor group.

a. *Pliers, retaining ring.* The pliers are required to assemble and disassemble the ring on the first stage piston pin assembly (par. 35b and 43i).

b. *Wrench internal socket with 1/4-inch square drive, 9/164 inch.* The socket wrench is required to apply torque to first and third stage head screws (par. 44m and 46n).

c. *Wrench, internal socket with 1/4-inch square drive, 5/32 inch.* The socket wrench is required to assemble and disassemble the gerotor (par. 36d and 42e).

d. *Wrench, internal socket with 1/4-inch square drive, 3/16 inch.* The socket wrench is required to apply torque to second stage head screws (par. 15o) and the fourth stage plug screws (par. 46p).

e. *Wrench, torque, 1/4,-inch square drive.* This torque wrench is used with the. 1/4-inch drive socket .

20. Equipment

a. *Test Stand.* A locally fabricated variable-speed-driven test stand, capable of delivering up to 3 horsepower, and incorporating a flowmeter, tachometer, high pressure reservoir, timeclock, gage and a mounting adapter is required for running in the reassembled basic

compressor (par. 47). The test stand is hooked up in the following manner. Mount variable speed drive to mounting base of test stand. Attach compressor to be tested to variable drive with mounting adapter. Connect a high pressure flexible hose to discharge fitting on compressor and connect other end to a high pressure tee. Attach 0-3000 psi gage to high pressure tee. Connect a high pressure flexible hose to free end of high pressure tee, then connect other end of hose to manually adjustable high pressure (0 to 300 psi) back pressure valve. Discharge port of back pressure valve may be connected with a high pressure flexible hose to a 208 t 3 cu. in. high pressure reservoir, when performing pump up test. Connect a flex hose with AN818 nut to blowby fitting located on bottom of compressor adaptor. Connect free end of flexible hose to 0 to 1 cfm flowmeter with vent to atmosphere.

Warning: Be extremely careful when fabricating, test stand that all components of the test stand are firmly secured to stand to prevent injury to personnel and damage to property. Observe safety procedures for working with high pressure pneumatic equipment.

b. *Ultrasonic Cleaner.* An ultrasonic cleaner using dry-cleaning solvent should be used for cleaning all metal parts. However, if the cleaner is not available, use a stiff bristle brush and clean all parts thoroughly with dry-cleaning solvent per Federal Specification P-S-661.

Section II. WATER SEPARATOR GROUP

21. Description

The water separator group consists of a shell, baffle assembly, cap, relief valve and various fittings and components to permit proper opera-

tion of the unit. The cap incorporates an inlet port, outlet port and a port for the installation of the relief valve. The inlet port, of the cap, is so oriented that it directs the inlet air to the

AGO 5548A

spiral baffle assembly located within the water separator. The outlet port is so oriented so as to minimize moisture carryover from the inlet port to the outlet port. The shell incorporates a drain port, at the lowest point, for drainage of any moisture collected in the shell. The water separator is designed for an operating pressure of 2,000 psi at a temperature range of + 32° F. to +160° F. The minimum accumulated water capacity of the water separator is 9.5 cu. in. The unit is mounted vertically to prevent carryover of moisture and to permit drainage. The water separator relief valve consists of a valve body enclosing a spring-loaded piston and ball. The valve body incorporates a threaded inlet for attachment to the water separator cap. The relief valve cap is used to adjust the relieving pressure and incorporates a port for venting the air to atmosphere. The relief valve maintains the upper limit of the operating air pressure, by venting excess air to atmosphere.

22. Function

The compressed air going into the water separator contains water vapor. During the compression phase, most of the water vapor is removed as water because, at high pressure, the air can no longer retain the same amount of water vapor. Before compressed air is made available for use, the water in liquid droplet form, in the compressed air, must be separated. The water separator performs this function by directing the incoming air-water mixture toward the water separator's internal baffle. The water droplets collect on the baffle and are directed to the lowest portion of the shell. In order to protect the air compressor during operation a relief valve is mounted on the water separator to provide a means of venting excess air. Venting occurs when the air pressure in the water separator -unseats the spring loaded piston in the relief valve.

23. Maintenance

Fourth echelon maintenance personnel are authorized to replace the fitting, elbow, name-plate, shell, baffle assembly, cap and required hardware. Replacement and overhaul of the water separator and repair of the relief valve are authorized at fourth echelon. The water separator, relief valve kit is used to repair the water separator relief valve.

- a. *Removal.* Remove the water separator from the frame assembly (par. 12a).
- b. *Disassembly.*
 - (1) Unscrew the relief valve (2, fig. 3) from cap (6) of the water separator. Remove the preformed packing (3) from the relief valve.
 - (2) Disassemble the water separator relief valve as described below.
 - (3) Remove the seal (9, fig. 7), tag (16), lockwire (10 and 17) and nameplate (15) from the relief valve.
 - (4) Loosen the lock nut (7) and unscrew the cap (1) from the body (8).
Warning: Be extremely careful when removing the cap from the body to prevent injury to personnel since the cap is compressing a spring.
 - (5) Remove the spring (2), retainer (3), ball (4), and piston (5) from the body (8).
 - (6) Remove the preformed packing (6) from the piston (5)
 - (7) Unscrew the lock nut (7) from the body (8).
 - (8) Unscrew the fitting (14) from the body (8).
 - (9) Remove the preformed packing (13) from the fitting (14)
 - (10) Remove the spring (12) and seat (11) from the body (8).
- c. *Cleaning and Inspection.*
 - (1) Clean metallic parts in ultrasonic cleaner.
 - (2) Inspect components for scratches, nicks, wear or other damage.
 - (3) Replace all parts supplied with the repair kit.
- d. *Lubrication.*
 - (1) Apply oil (OE-30) to preformed packings.
 - (2) Apply oil (OE-30) to all threaded areas.
Caution: Do not use grease on this relief valve during reassembly.
- e. *Assembly (fig. 7).*
 - (1) Position the preformed packing (13) onto the fitting (14)
 - (2) Position the spring (12) and seat (11) into the fitting (14).
 - (3) Screw the fitting (14) into the body

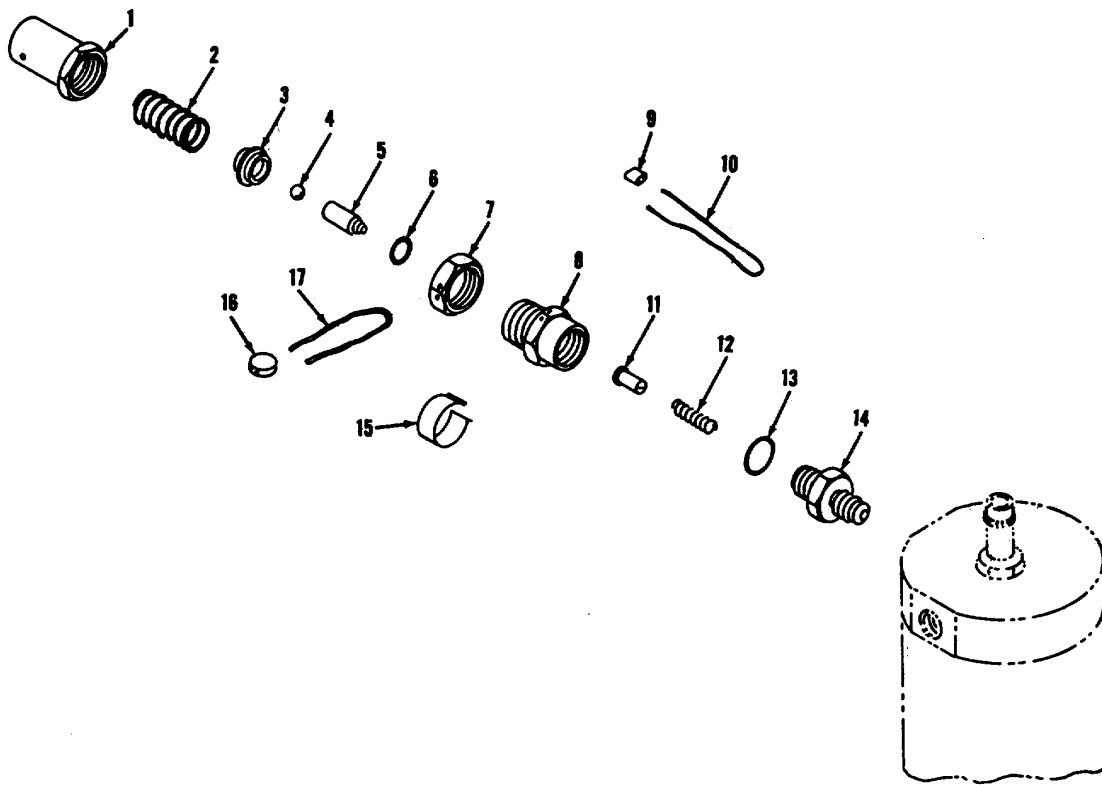

- 1 Cap
- 2 Spring
- 3 Retainer
- 4 Ball
- 5 Piston
- 6 Preformed packing
- 7 Lock nut
- 8 Body

- 9 Seal
- 10 Lockwire
- 11 Seat
- 12 Spring
- 13 Preformed packing
- 14 Fitting
- 15 Nameplate
- 16 Tag

17 Lockwire

Figure 7. Water separator relief valve, exploded view

- (8) and apply a torque to the fitting of 25 pound-feet.
- (4) Position the preformed packing (6) into the body (8).
- (5) Screw the locknut (7) onto the body (8).
- (6) Wipe oil (OE30) on the inside diameter of the body (8) and then insert the piston (5) into the body.
- (7) Hold the cap (1), with the opening up, and drop the spring (2), spring retainer (3) into the cap. Center the ball (4) in the spring retainer. Assemble the body and the cap.

- (8) Assemble the nameplate (15) after proper stamping of the part number and pressure setting.
- (9) Perform the test and calibration as indicated in f below.
- (10) Secure the cap (1) and body (8) together using the lockwire (17) and tag (16). Secure the body, fitting (14) and locknut (7) together using the seal (9) and lockwire (10).
- (11) Recheck the full flow and reseal pressure after lockwiring to make certain that the setting adjustment has not been changed.

AGO 5548A

f *Test and Calibration (fig. 7).*

- (1) Connect the relief valve to a high pressure pneumatic supply.

Warning: Be extremely careful when working with pneumatic equipment to prevent injury to personnel and damage to property resulting from careless handling or possible equipment failure. Perform all testing in an assigned area, cleared of all unauthorized personnel. Make certain all equipment is properly cleared and secured. Clamp all pneumatic equipment being tested firmly in a vise or other suitable testing fixture. Do not attempt to adjust or disassemble equipment under pressure. Use a heavy metal shield, equipped with suitable safety glass windows to protect personnel whenever proof pressure testing.

- (2) Back off the locknut (7) and adjust the cap (1) until the relief valve is passing full flow at 2,275 + 25 psi. Pressure cycle the valve slowly ten times from full open to zero inlet

pressure. Full flow should be 3.0 c.f.m. of air.

- (3) With the cap (1) adjusted so that a full flow of 3.0 c.f.m., of air is relieved at 2,275 ± 25 psi and the relief valve reseats at 1,950 psi, lock the cap in place with locknut 47).

- (4) With the relief valve adjusted and locked in position, apply pressure slowly to 2,275 - 25 psi so that the relief valve is relieving full flow of 3.0 c.f.m. Slowly decrease the inlet pressure to 1,950 psi so that the relief valve reseats. Allow one minute for the relief valve to stabilize and then determine leakage of the relief valve. The measured leakage for one minute shall not exceed 3 cc of air.

g. *Installation (fig. 3).*

- (1) Position the preformed packing (3) onto the relief valve (2).
- (2) Screw the relief valve (2) into the cap (6) of the water separator. Torque the relief valve between 3 to 5 pound-feet.
- (3) Install the water separator on the frame (par. 12f).

Section III. FAN GROUP

24. Description and Function

The fan group consists of a fan, fan guard, and attaching hardware. The fan consists of five vanes shaped in such a manner that in rotation the fan propels air over the compressor. The fan guard consists of concentric wire rings mounted on four brackets. The inner portion of the fan guard is covered by a circular metal plate. When positioned and mounted on the compressor, the fan serves to move the cooling air in and around the intercoolers. The fan guard prevents external interference with the rotation of the fan and provides protection for personnel and the fan itself.

25. Maintenance

Fourth echelon maintenance personnel are authorized to replace the fan, fan guard, fan nut, and attaching hardware.

a. *Removal (fig. 8).*

Warning: Do not attempt removal of any

component in the fan guard section while the compressor is in operation.

- (1) Remove the screws (5), washers (6) and the fan guard (4).
- (2) Secure the pulley on the gasoline engine to prevent rotation of the crank-shaft, unscrew the nut (3), and remove the washer (2) and fan (1).

b. *Cleaning and Inspection.*

- (1) Clean all metallic parts in ultrasonic cleaner.
- (2) Inspect components for scratches, nicks, distortion and other damage.

c. *Installation.*

- (1) Secure the pulley on the engine to prevent rotation of the crankshaft. Position the fan (1, fig. 8) on the compressor crankshaft and secure with the washer (2) and fan nut (3). Torque the fan nut to 17 pound-feet.

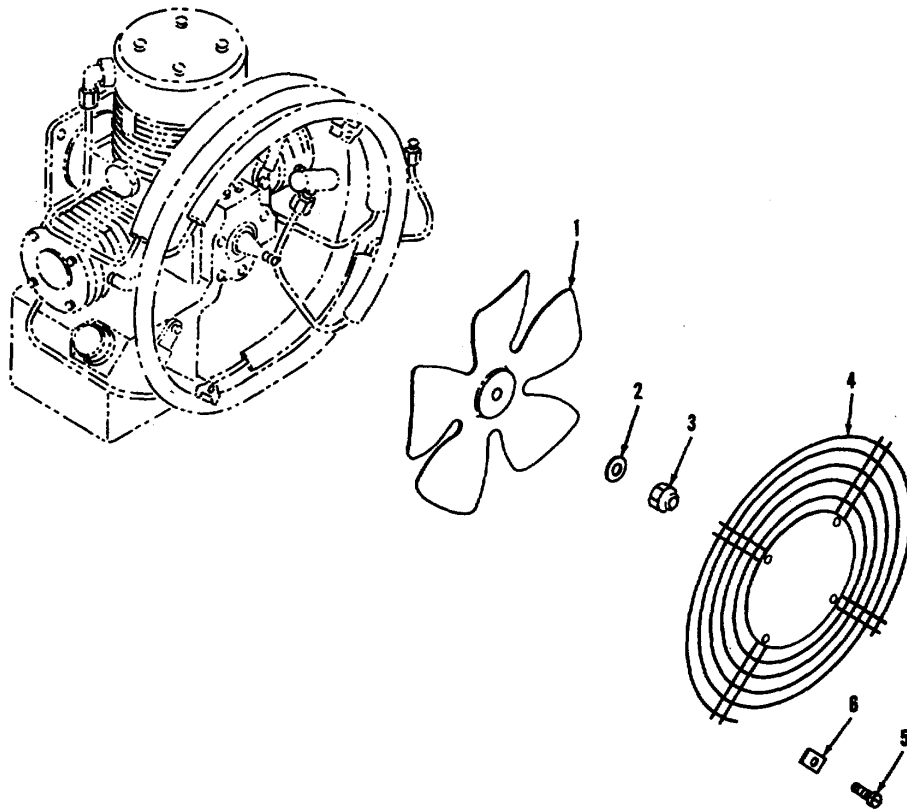

- 1 Fan
- 2 Washer
- 3 Nut

- 4 Fan guard
- 5 Screw
- 6 Washer

Figure 8. Fan and fan guard, exploded view.

(2) Position the fan guard (4) on the brackets (1 and 9, fig. 9) and secure

with the screws (5, fig. 8), washers (6).

Section IV. INTERCOOLER AND AFTERCOOLER SECTION

26. Description and Function

The intercooler and aftercooler section consists of the first stage intercooler, second stage intercooler, aftercooler, fan guard brackets, cooler clamps, and the hardware required to secure the components. The intercoolers and aftercoolers are made of corrosion resistant steel tubing with tin coated, low carbon steel fins soldered to the tubing. The end fittings of the coolers consist of sleeves and nuts positioned at the flared ends of the tubing. The intercoolers and aftercooler are positioned

around the fan and serve to cool the compressed air passing from one stage to another. The moisture in the compressed air is both squeezed out and condensed by cooling. The entrained moisture is separated from the compressed air by the water separator.

27. Maintenance

Fourth echelon maintenance personnel are authorized to replace the first stage intercooler, second stage intercooler, aftercooler, fan guard brackets, and attaching hardware.

AGO 5548A

a. *Removal (fig. 9).*

(1) Remove the fan guard section (par. 25a).

(2) Loosen the end nuts attaching the first stage intercooler (5), the second stage intercooler (7) and the after-cooler (6) to the basic compressor.

(3) Remove the two locknuts (12) and two washers (14); remove the large clamp (2).

(4) Remove the locknut (13) and washer (11) and remove the short clamp (8). The second stage intercooler (7), the after-cooler (6), and the first stage intercooler (5) can then be removed from the compressor.

(5) Remove the screw (4) and washer (3) and remove the fan bracket (1).

(6) Remove the fiat screw (10) and remove the short bracket (9).

b. *Cleaning and Inspection.*

(1) Clean all metallic parts in ultrasonic cleaner.

(2) Inspect components for scratches, nicks, distortion and other damage.

(3) Inspect the cooling coils for bent fins.

(4) Replace all damaged components.

c. *Installation.*

(1) Position and loosely secure the short bracket (9, fig. 9) to the compressor using the screw (10).

(2) Position and loosely secure the fan bracket (1) to tile compressor using the washer (3) and screw (4).

(3) Assemble the fan guard (4, fig. 8) to the fan guard brackets (1 and 9, fig. 9) using the' screws (5, fig. 8), washers (6) in order to properly orient the brackets. Tighten the screws (4 and 10, fig. 9) securely; remove the fan guard, screws and washers.

(4) Position the first stage intercooler (5, fig. 9) to the elbow (8, fig. 13), which is attached to the 1st stage discharge port of the compressor, and to the elbow (4, fig. 12), which is attached to the second stage inlet port of the compressor, matching the fins on the Section V.

intercooler with the edges of the brackets (1 and 9, fig. 9). Secure the first stage intercooler (5) by applying a torque of 3 to 5 pound-feet to the intercooler nuts.

(5) Position the aftercooler (6) to the elbow (13, fig. 11) and to the elbow (12, fig. 3) on the water separator, matching the fins on the aftercooler with the edges of the brackets (1 and 9, fig. 9). Secure the aftercooler (6) by applying a torque of 3 to 5 pound-feet to the aftercooler nuts.

(6) Position the second stage intercooler(7)to the elbow (3, fig. 12) and to the second stage relief valve (17, fig. 11) matching the fins on the inter-cooler with the edges of the brackets (1 and 9, fig. 9). Secure the second stage intercooler by applying a torque of 3 to 5 pound-feet to the intercooler nuts.

(7) Position the large clamp (2) on the fan bracket (1) placing the clamp between the fins on the cooling coils. Secure the clamp to the fan bracket using the washer (14) and nut (13). Apply a torque of 4 to 5 pound-feet to the nut.

(8) Position the short clamp (8) on the short bracket (9) placing the clamp between the fins on the cooling coils. Secure the clamp to the bracket using the washer (11) and nut (12). Apply a torque of 4 to 5 pound-feet to the nut.

(9) Mount the fan guard (4, fig. 8) to the fan guard brackets (1 and 9, fig. 9) with washers (6, fig. 8), screws (5, fig. 8) to check the orientation of the brackets. Remove the fan guard, washers, and the screws. With the fan guard brackets properly oriented and the screws (4 and 10, fig. 9) firmly secured lockwire the screws. Mount the fan guard on the brackets with the washers and screws.

Section V. COMPRESSOR GROUP

28. Description

The compressor group consists of five different sections. These sections are the third stage

section, second stage section, first stage section, keystone-crankshaft section, and crankcase section.

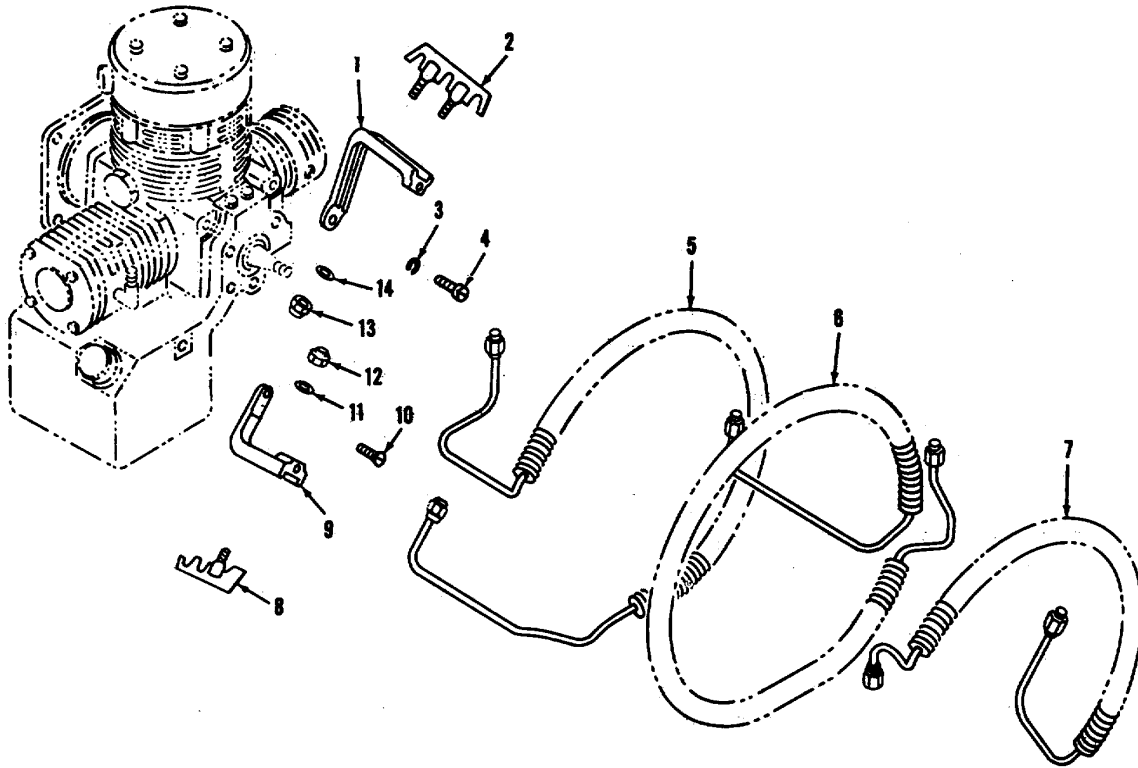

Figure 9. Intercooler and after

- | | |
|-------------------|-----------------|
| 1 Fan bracket | 8 Short clamp |
| 2 Large clamp | 9 Short bracket |
| 3 Washer | 10 Screw |
| 4 Screw | 11 Washer |
| 5 1st intercooler | 12 Nut' |
| 5 Aftercooler | 13 Nut- |
| 7 2d intercooler | 14 Washer |

a. Third Stage Section. The third stage section consists of an outlet elbow, second stage relief valve, head assembly, valve plate, plunger and cylinder, discharge valve, inlet valve, discharge spring, inlet spring, shim, gaskets, preformed packings, and attaching hardware.

b. Second Stage Section. The second stage section consists of an inlet elbow, outlet elbow, head assembly, second stage valve plate, inlet valve, gaskets, shim, ring, inlet spring, discharge valve, discharge spring, second stage plunger assembly, and the attaching hardware.

c. First Stage Section. The first stage section consists of an outlet elbow, cap, first stage filter assembly, head assembly, discharge seat, valve plate, piston plug, piston pin assembly,

first stage piston, shims, retaining ring, lock-ring, discharge valve, discharge spring, head seal, and required attaching hardware.

d. Keystone-crankshaft Section. The key-stone-crankshaft section consists of the adapter, connector, keystone assembly, backup plate, front bearing, rear bearing, gerotor assembly, crankshaft assembly, retaining ring, packings, and attaching hardware.

e. Crankcase Section. The crankcase section consists of the retainer spring, oil pump shim, guide, pump ball, relief valve seat, strainer retainer, strainer spring, strainer assembly, cap, connector, drain plug, preformed packings, gage rod cap, spring tension washer, tube assembly, fourth stage plug, crankcase, pump

AGO 5548A

spring, pin, oil seal, front seal, and the attaching hardware.

29. Functioning

The compressor sections are joined together to form a single working unit. The first, second, and third stage sections are assembled to the crankcase section. The keystone-crankshaft section is located within the crankcase section.

a. Keystote-Crankcase Section. The keystone-crankcase section, when powered by the gasoline engine, provides oil pressure to the unit by the use of the gerotor and also activates the first, second, and third stage sections.

b. First Stage Section. The first stage section filters and draws air into the first stage cylinder bore on the downward stroke of the first stage piston. On the upward stroke of the first stage piston, the inlet valve seats on the valve plate and the discharge valve unseats permitting the compressed air to flow through the first stage intercooler to the inlet port of the second stage section.

c. Second Stage Section. The second stage section accepts the low pressure compressed air, which unseats the inlet valve in the second stage. The low pressure air forces the second stage plunger downward to follow the key-stone on the crankshaft. The rotation of the crankshaft moves the keystone in a circulatory manner so that at the bottom of the downward stroke, the second stage plunger is forced in the reverse direction. On the upward stroke, the second stage plunger starts to compress the air in the second stage cylinder bore. As soon as the air pressure in the second stage is greater than the incoming air from the first stage section, the second stage inlet valve seats on the valve plate. The discharge valve is unseated permitting passage of the intermediate pressure from the second stage section to the second stage intercooler, second stage relief valve and the inlet port of the third stage section.

d. Third Stage, Section. The third stage section accepts the intermediate pressure which unseats the inlet valve in the third stage. The intermediate pressure forces the third stage plunger downward to follow the keystone on

the crankshaft. On the upward stroke the third stage plunger compresses the air in the third stage cylinder bore, as the inlet valve seats on the third stage 'valve plate. As the pressure within the third stage cylinder starts to exceed the pressure on the outlet side of the discharge valve the discharge valve unseats permitting the high pressure compressed air to pass to the aftercooler and the water separator.

30. Maintenance

Fourth echelon maintenance personnel are authorized to test and overhaul the compressor group. Overhaul of the compressor group is accomplished by replacement and overhaul of detail components and attaching hardware in each section, using repair part kits for each section.

a. Thlrd Stage Section. Third stage section overhaul is accomplished by replacing the elbow fitting, second stage relief valve, head assembly, valve plate, plunger and cylinder, and spacer.

Caution: The plunger and- cylinder are matched parts and are not replaceable separately.

Repair parts for the third stage section are included in the third stage repair kit.

b. Second Stage Section. Second stage section overhaul is accomplished by replacing the inlet elbow, outlet elbow, head assembly, second stage valve plate, washers, and second stage plunger assembly. Repair parts are included in the second stage repair kit.

c. First Stage Section. First stage section overhaul is accomplished by replacing the outlet elbow, cap, head assembly, discharge seat, valve plate, spacer, piston plug, piston pin assembly, and first stage piston. Repair parts are included in the first stage repair kit.

d. Keystone-crankshaft Section. Keystone-crankshaft section overhaul is accomplished by replacement of the connector, adapter assembly, back-up plate, keystone assembly, front bearing, rear bearing, crankshaft assembly, gerotor assembly, and retaining ring.

Caution: The keystone assembly consists of matched parts and is not interchangeable with similar parts of other keystone assemblies.

e. Crankcase Section. Crankcase section overhaul is accomplished by the replacement of

the spring retainer, pump shim, guide, pump ball, relief valve seat, strainer retainer, strainer spring, strainer assembly, cap, connector, fourth stage plug, packing, and crankcase. Repair parts are included in the crankcase repair kit.

31. Removal

(fig. 10)

Note. Prior to removal of the compressor group, clip and remove all lock wire and drain the oil sump.

a. Remove the fan guard section (par. 25a) and intercooler and aftercooler section (par. 27a).

b. Remove the four machine bolts (2) and four washers (1) and remove the compressor assembly (3) from the gasoline engine.

32. Third Stage Section Disassembly

(fig. 11)

a. Unscrew the second stage relief valve (17) and elbow fitting (13) from the head assembly (14).

b. Unscrew the four screws (16) and washers (15) and remove the head assembly (14).

c. Remove the gaskets (11 and 12), discharge valve spring (10), and the discharge valve (9) from the valve plate (8).

d. Remove the valve plate (8), gasket (7), inlet valve (6), and inlet valve spring (5) from the cylinder and plunger assembly (4).

e. Remove the cylinder and plunger (4) from the crankcase and remove the spacer (3), shim (2), and preformed packing (1).

Note. The cylinder and plunger are matched parts. Do not separate the cylinder and plunger or mix with similar components of other compressors.

f. Unscrew the four screws (22) and washers (20) and remove the plug (19).

g. Remove the preformed packing (18) from the plug (19).

33. Second Stage Section Disassembly

(fig. 12)

a. Unscrew and remove the elbows (3 and 4) from the head assembly (5); unscrew the four screws (1) and washers (2) then remove the head assembly.

b. Remove the gaskets (6 and 7), spring (8), valve (9) from the valve plate (10). Remove the valve plate, valve (11), spring (12), spacers (13 and 14), shim (15), and the

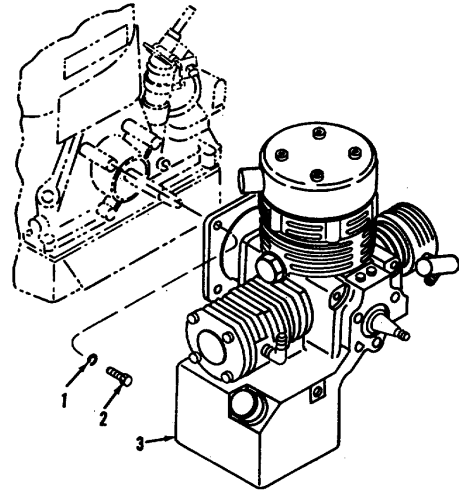

1 Washer
2 Machine bolt
3 Compressor assembly

Figure 10. Removing compressor group, exploded view.

plunger assembly (18) from the crankcase.

c. Remove the three rings (16) from the plunger subassembly (17).

34. First Stage Valve Disassembly

(fig. 13)

a. Unscrew and remove the elbows (8) from the head assembly (7). Remove the four screws (19) and washer (20) and remove the cap (21)

b. Remove the filter cap (22) from the head assembly (7). Remove the preformed packing (23) from the filter cap.

c. Remove the filter assembly (24) from the head assembly (17).

d. Unscrew the six screws (5) and washers (6) and remove the valve and head assembly from the valve plate (15). Remove the preformed packing seal (11) from the head assembly (7).

e. Straighten and remove the cotter pin (18). Unscrew the nut (9) and washer (10) and remove the screw (17), gasket (16), seat (14), valve (13), and spring (12) from the head assembly (7).

AGO 5548A

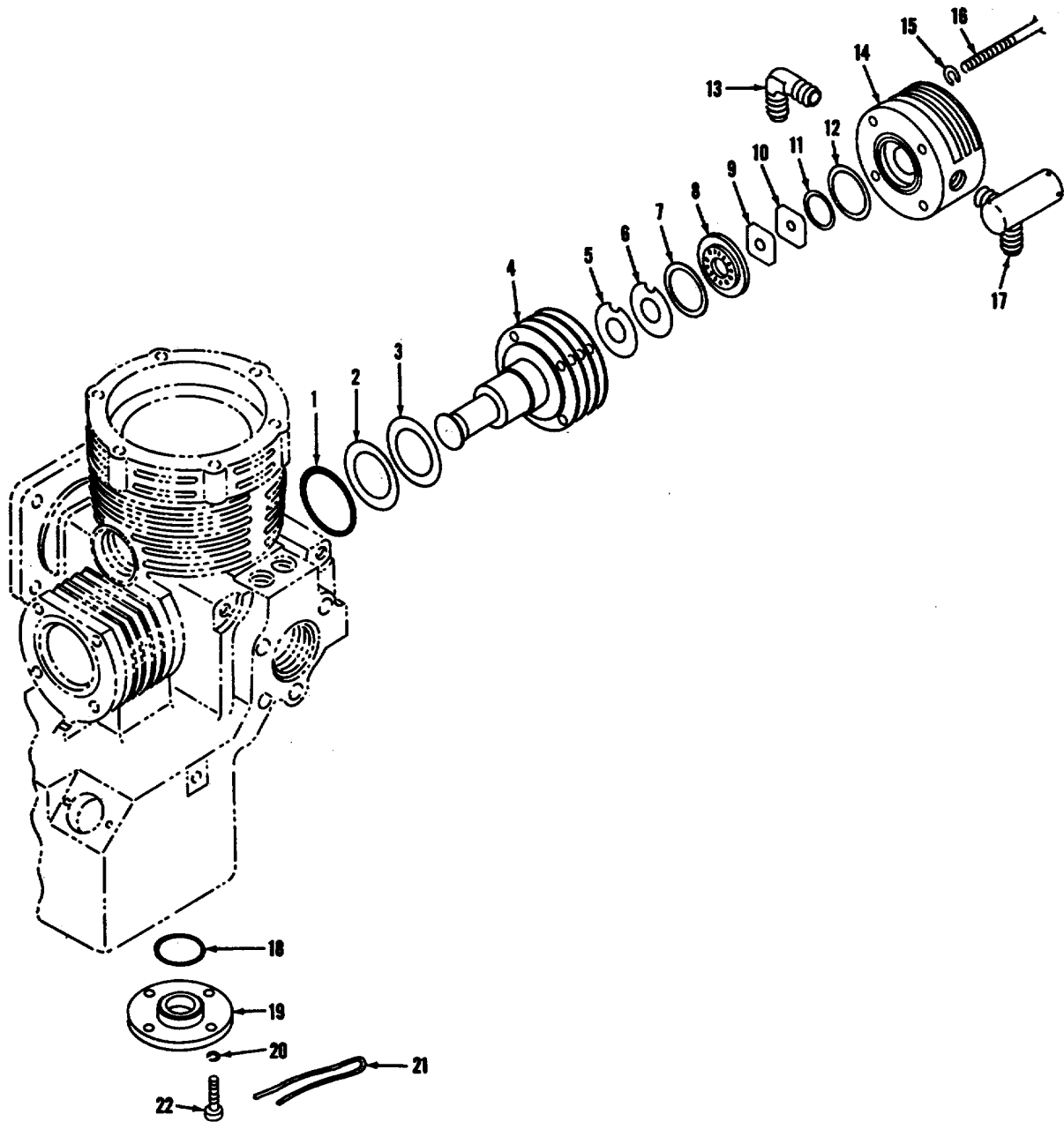

- | | | | |
|----|-------------------------------|----|-------------------|
| 1 | Preformed packing | 12 | Gasket |
| 2 | Shim | 13 | Elbow |
| 3 | Spacer | 14 | Head assembly |
| 4 | Plunger and cylinder assembly | 15 | Washer |
| 5 | Inlet valve spring | 16 | Screw |
| 6 | Inlet valve | 17 | Relief valve |
| 7 | Gasket | 18 | Preformed packing |
| 8 | Plate | 19 | 4th stage plug |
| 9 | Discharge valve | 20 | Washer |
| 10 | Discharge valve spring | 21 | Lockwire |
| 11 | Gasket | 22 | Screw |

AGO 1148A

Figure 11. Third stage section, exploded view.

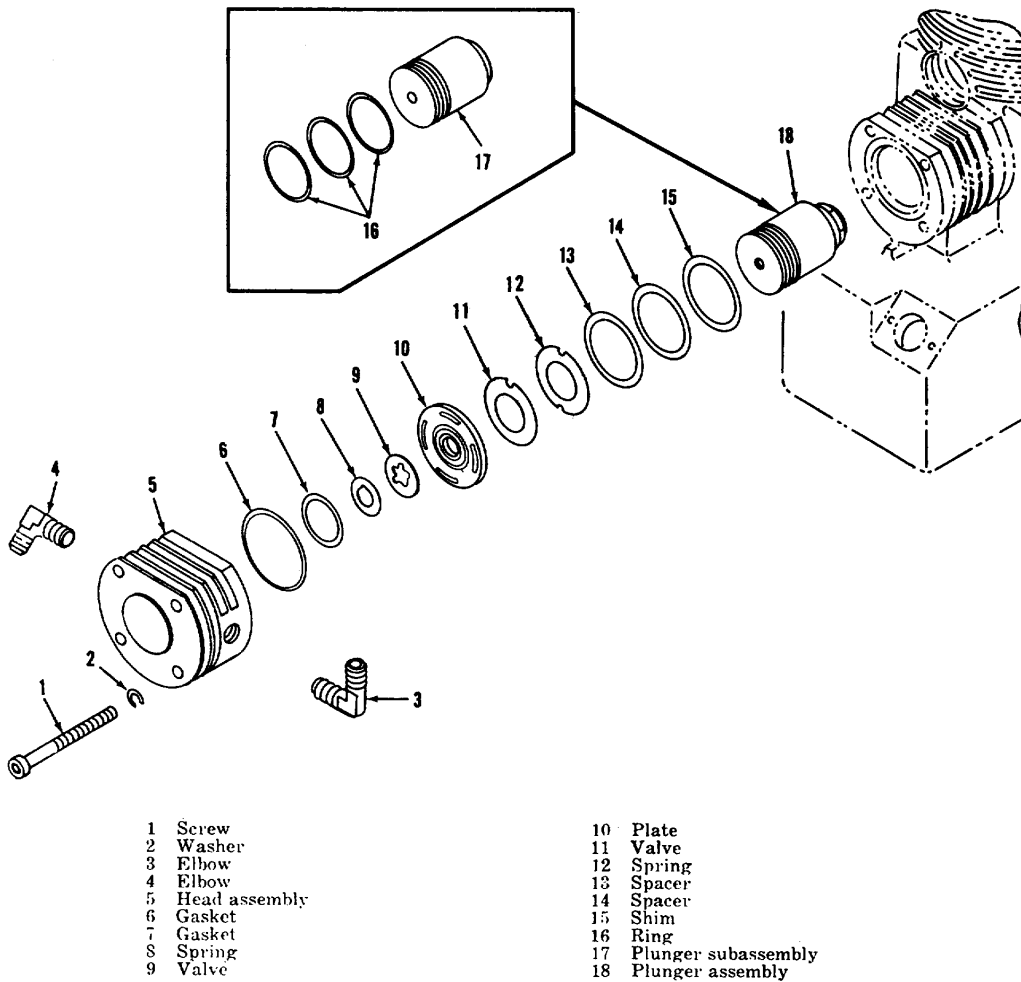

Figure 12. Second stage section, exploded view.

35. First Stage Piston Disassembly (fig. 14)

- a. Unscrew the plug (4) from the crankcase and remove the preformed packing (5).
- b. Remove ring (6) using ring pliers; remove the piston pin, ring, and shim assembly from the piston (3).
- c. Remove the ring (7), shims (8, 9, and 10) from the piston pin assembly (11).
- d. Remove the piston and piston ring assembly from the first stage cylinder bore.
- f. Remove the valve plate (15), gasket (1), valve (2), spacer (3) and shim (4) from the crankcase.

- e. Remove the ring (2) and the piston rings (1) from the piston (3).

36. Keystone-Crankshaft Section Disassembly (fig. 15)

- a. Unscrew the connector (22) from the adapter (3).
- b. Unscrew the four screws (1) and washers (2) and remove the adapter (3) from the compressor assembly. Remove the preformed packing (4) from the adapter.

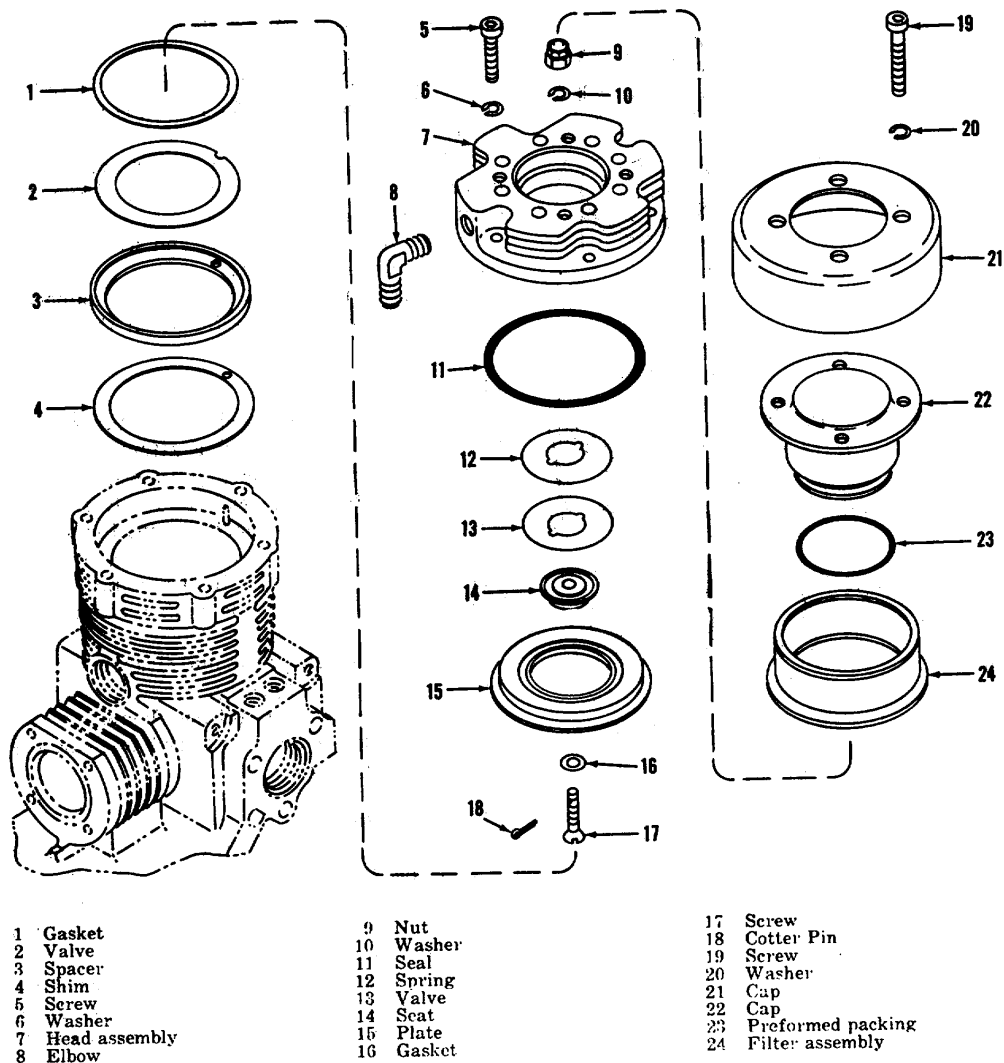

Figure 13. First stage valve, exploded view

c. Remove the wave washer (5) and oil seal (6) from the rear of the crankshaft (11). Remove the ring (18), oil seal (17), and the preformed packing (16) from the front of the crankshaft.

d. Unscrew the three screws (19) and washers (20 and 21) and using 5/32-inch socket wrench, remove the crankshaft, bearings and gerotor assembly from the crankcase.

e. Remove the gerotor assembly (15), pin. (12), and plate (14) from the front of the crankshaft.

f. Press or drive the two rollpin assemblies (9) out of the keystone assembly (23) and remove the upper keystone (8) and lower keystone (10) from the crankshaft (11).

Note.

The keystone assembly consists of matched parts; keep together and separate from similar assemblies of other compressors.

g. Remove the front bearing (13) and rear 23

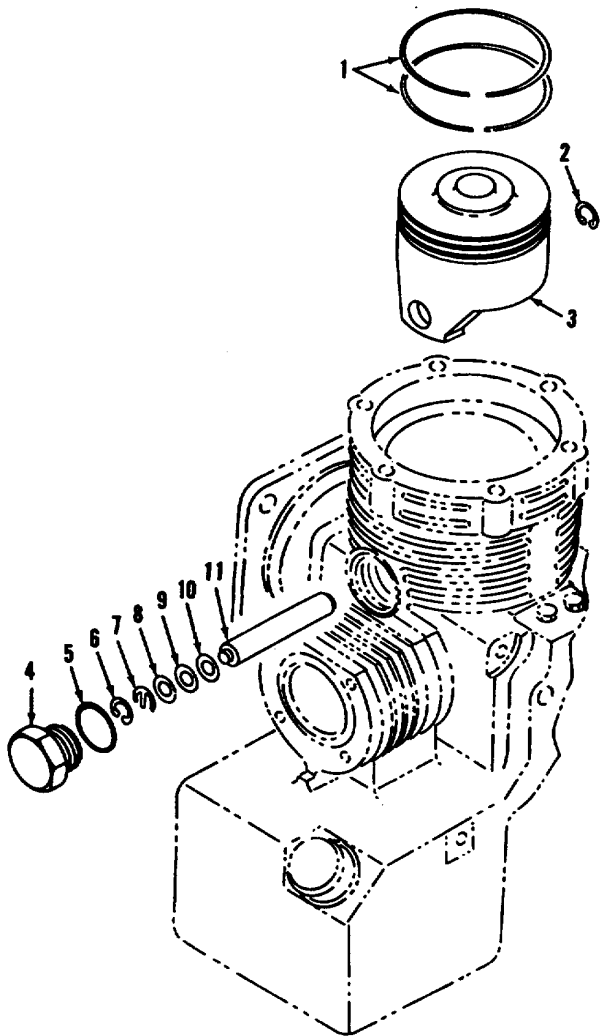

- 1 Ring
- 2 Ring
- 3 Piston
- 4 Plug
- 5 Preformed packing
- 6 Ring
- 7 Ring
- 8 Shim
- 9 Shim
- 10 Shim
- 11 Pin assembly

Figure 14. First stage piston, exploded view.

bearing (7) from the crankshaft using a bearing puller or brass drift and hammer.

37. Crankcase Section Disassembly (fig. 16)

a. Unscrew the spring retainer (1) and re 24 move the preformed packing (2) from the spring retainer.

b. Remove the shim (3), spring (4), guide (5), ball (6), and seat (7) from the crankcase (14).

c. Unscrew the strainer retainer (8) and remove the preformed packing (9) from the strainer retainer.

d. Remove the spring (10) and strainer (11) from the crankcase (14).

e. Unscrew the cap (12) from the connector (13); unscrew the connector from the crankcase.

38. Cleaning

a. Use a soft brush to clean apertures, slots, and holes, paying particular attention to the crankcase and crankshaft passages. Remove carbon deposits in the heads and valves.

b. Clean all metallic parts except the crankcase (14, fig. 16), rear bearing (7, fig. 15) and front bearing (13, fig. 15) in ultrasonic cleaner. Blow strainers dry with clean, dry, compressed air.

c. Use an oil base ultrasonic cleaner to clean the crankcase (14, fig. 16).

Caution

Under no condition should a water base ultrasonic cleaner be utilized to clean any cast iron component.

39. Inspection

a. Inspect all parts visually for obvious signs of wear or damage.

b. Inspect all internal and external threads and discard any part having more than two damaged threads in any one location.

c. If the crankshaft has been disassembled, measure the diameters of the shaft. The front bearing seating surface should be between 1.2501 and 1.2505 in O.D. The rear bearing seating surface should be between 1.5749 and 1.5753 in O.D. The keystone assembly seating surface should be between 0.8750 and 0.8753 in O.D.

d. If the keystone assembly has been disassembled, measure the diameters of the keystone bores. The crankshaft bore of the keystone assembly should be between 0.8759 and 0.8763 in I.D. The first stage piston pin bore of the keystone assembly should be between 0.5008 and 0.5012 in I.D.

e. Inspect the valves and valve seats to see

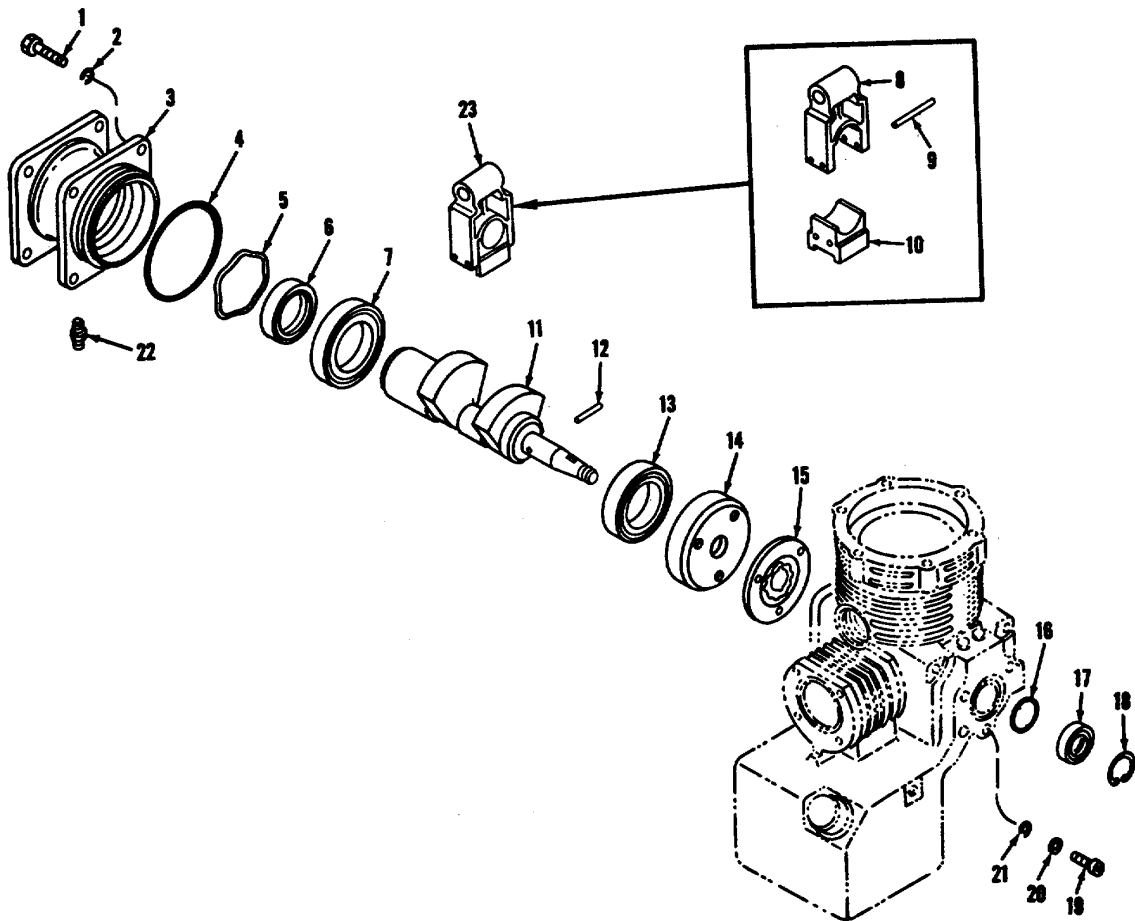

- | | | | | | |
|---|-------------------|----|-------------------|----|-------------------|
| 1 | Screw | 9 | Rollpin assembly | 17 | Seal |
| 2 | Washer | 10 | Lower keystone | 18 | Ring |
| 3 | Adapter | 11 | Crankshaft | 19 | Screw |
| 4 | Preformed packing | 12 | Pin | 20 | Washer |
| 5 | Wave washer | 13 | Front bearing | 21 | Washer |
| 6 | Seal | 14 | Plate | 22 | Connector |
| 7 | Rear bearing | 15 | Gerotor assembly | 23 | Keystone assembly |
| 8 | Upper keystone | 16 | Preformed packing | | |

Figure 15. Keystone-crankshaft, exploded view.

that they are free of nicks, scratches, or burrs.

f. Inspect all cylinder bores to determine that the internal surfaces are free of nicks, scratches, chipping, carbon deposits, or any unusual wear patterns.

g. Inspect all plungers and pistons to determine that the outside wear surfaces are free of nicks, scratches, burrs, or carbon deposits. Check that the piston ring grooves are free of carbon.

h. Inspect the outside surface of the piston pin assembly (11, fig. 14) to determine that the pin is round and free of nicks, scratches,

or burrs. Measure the O.D. and check that it is between 0.5001 and 0.4998 inch.

i. Inspect the oil sump of the crankcase (14, fig. 16) and determine that the sump is free of dents or abrasions that might develop into leaks.

j. Inspect ports, bores and pressure relief holes in the crankcase (14, fig. 16) for cleanliness and clogging.

k. Replace all defective components, preformed packings, springs, and parts furnished in the repair kit allocated to fourth echelon maintenance personnel.

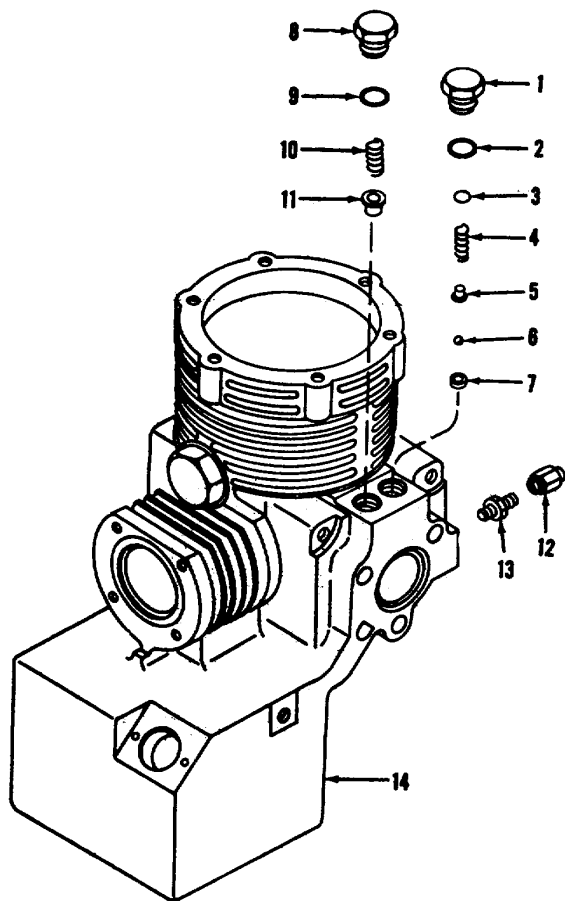

- 1 Spring retainer
- 2 Preformed packing
- 3 Shim
- 4 Spring
- 5 Guide
- 6 Ball
- 7 Seal
- 8 Strainer retainer
- 9 Preformed packing
- 10 Spring
- 11 Strainer
- 12 Cap
- 13 Connector
- 14 Crankcase

Figure 16. Crankcase, exploded view.

40. Lubrication

- a. Apply oil (OE-0) to all preformed packings.
- b. Apply oil (OE30) to all threaded areas.
- c. Apply oil (OE-30) to all wear surfaces.
- d. Apply oil (OE-30) to the front and rear bearings (7 and 18, fig. 15).

41. Crankcase Assembly (fig. 16)

- a. Screw the connector (13) securely into the crankcase (14) then assemble the cap (12) to the connector.
- b. Position the preformed packing (9) on the strainer retainer (8).
- c. Position the strainer (11), spring (10), into the oil return port in the crankcase (14); secure the strainer retainer (8) into the oil return port and tighten securely.
- d. Position the preformed packing (2) onto the spring retainer (1).
- e. Position the seat (7), ball (6), guide (5), spring (4), shim (3) into the oil pressure relief port in the crankcase (14); screw the spring retainer (1) into the oil pressure relief port and tighten securely.

42. Keystone-Crankshaft Assembly (fig. 15)

- a. Using an arbor press, press the front bearing (13) and rear bearing (7), one at a time, onto the crankshaft (11) until the bearings shoulder.

Caution

Exert pressure on the inner race of the bearings only, to prevent damage to the bearing's rotating elements during installation.

- b. Position the upper keystone (8) and lower keystone (10) ("F" on both components facing the fan end on the compressor) onto the keystone bearing surface of the crankshaft (11); secure in place by pressing the two rollpin assemblies (9) into the keystone bearing surface of the crankshaft; press the two rollpin assemblies into the keystone assembly (23). The gaps in the two rollpin halves should be oriented 180° apart during installation and pressed flush with the keystone assembly surface.

Note

The upper and lower keystone are selective fits and are not interchangeable with similar parts. During assembly if the keystone assembly binds on the crankshaft, it may be loosened by tapping the upper and lower keystone with a plastic or rawhide mallet.

- c. Position the plate (14) onto the crankshaft (11) in front of the front bearing (13).
- d. Insert the pin (12) into the crankshaft (11) and position the gerotor assembly (15) onto the pin.

Note

The double.. keyway on the gerotor assembly (15) must be a free fit over the pin (12). If this is not so, turn the gerotor assembly over so that the face that was facing forward now faces backward and try for a free fit. The identification marks on the inner and outer gerotor assembly must be facing in the same direction.

e. Insert the crankshaft keystone assembly into the crankcase (14, fig. 16) after aligning the holes in the gerotor assembly (15, fig. 15), with the holes in the plate (14), and secure the plate to the crankcase using the three screws (19), washers (20) and washers (21). Using the 5/32-inch socket wrench and a torque wrench, torque the three screws between 2 and 3 pound-feet.

f. Position the preformed packing (4) into the groove on the adapter (3).

g. Position the oil seal (6) onto the crankshaft (11) together with wave washer (5) and adapter (3). Secure the adapter to the crankcase (14, fig. 16) using the four screws (1, fig. 15) and four washers (2). Apply a torque to the four screws (1) of between 5 to 7 pound-feet.

h. Screw the connector (22) into the adapter (3) and tighten.

i. Position the preformed packing (16), oil seal (17) onto the front end of the crankshaft (11) and secure in place with ring (18).

43. First Stage Piston Assembly

a. Rotate the crankshaft (11, fig. 15), using a piece of suitable size hexagonal bar stock until the piston pin hole, in the upper keystone (8) is in line with the piston pin port of the first stage cylinder of the crankcase (14, fig. 16).

b. Assemble the two piston rings (1, fig. 14) in the grooves of the first stage piston (3), 180° apart.

c. Assemble the ring (2) into the groove in the piston pin orifice on the first stage piston (3).

d. Preassemble the piston pin assembly (11) to the piston (3) for the proper selection of required piston pin shims (8, 9, and 10) as described in e through g below.;

e. Position the piston pin assembly (11) into the piston pin orifice opposite the orifice with the truarc ring (2). Follow with the shims (8, 9, and 10), ring (7) and ring (6).

f. Determine the end play of the piston pin assembly (11) using a dial indicator. Remove or add shims (8, 9, and 10) as required to obtain a piston pin assembly end play of not more than 0.001 inch. Shimming must allow for free rotation of the piston pin assembly while restricting the end play to a minimum.

g. Disassemble the rings (6 and 7), shims (8, 9, and 10) used to obtain the proper end play and piston pin assembly (11) from the first stage piston (3).

h. Using two small blocks of wood to compress the rings, position the first stage piston (3) into the crankcase (14, fig. 16), the mark "F" on the piston facing the fan end, so that the piston pin hole in the piston is aligned with the piston pin port in the crankcase and the piston pin orifice in the upper keystone (8, fig. 15). Insert the piston pin assembly (11, fig. 14) into the first stage piston through the piston pin port of the crankcase (14, fig. 16) and follow with the previously selected shims (8, 9, and 10, fig. 14) and the ring (7).

i. Assemble the ring (6) into the groove in the piston (3) using ring pliers.

j. Position the preformed packing (5) on the plug (4) and screw the plug into the piston pin port of the crankcase (14), fig. 16) end tighten securely.

44. First Stage Valve Assembly

a. Determine the thickness of shim (4, fig. 13) required to give a proper first stage head clearance between 0.013 to 0.017 inches as described in b through i below; refer to figure 17.

b. Position the first stage piston (3, fig. 14) to top dead center by rotating the crankshaft (11, fig. 15) using a suitable size hexagonal bar stock.

c. Position the spacer (3, fig. 13) and gasket (1) into the first stage cylinder bore.

d. Using a depth micrometer, measure the distance from the flat surface of the first stage cylinder of the crankcase (14, fig. 16) to the top of the piston (3, fig. 14). Record this valve as the "A" value.

e. Measure the distance from the flat surface of the first stage cylinder to the top of the gasket (1, fig. 13). Record this distance as the "B" value.

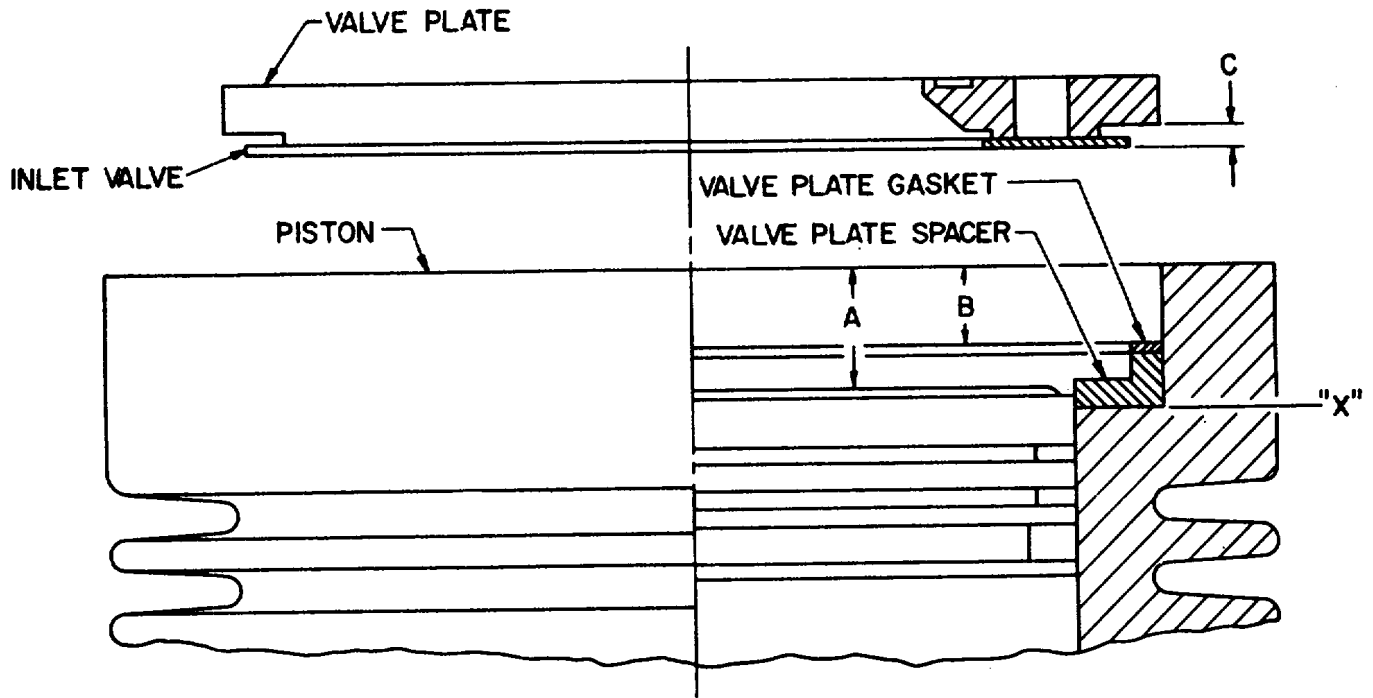

NOTE:
MEASUREMENTS TAKEN WITH PISTON
AT TOP DEAD CENTER.

CALCULATIONS:
 $B + C = D$
 $A - D = E$
E = TOTAL HEAD CLEARANCE
 $E - 0.015 \pm .002 = \text{THICKNESS}$
OF SHIM

Figure 17. First stage head clearance.

f. Position the intake valve (2) on the intake valve seating surface on the valve plate (15) and measure the distance from the valve to the flat on the valve plate. Record this value as the "C" value.

g. Determine the total available first stage head clearance by adding the values of "B" and "C" obtaining a sum value equal to "D".

Subtract the value of "D" from the value of "A" and obtain a remainder value of "E". This value "E" is the total head clearance for the first stage.

h. Subtract the required first stage head clearance of 0.015 + .002 inches from the "E" value and record this value as the thickness of shim (4).

i. Remove the spacer (3) and gasket (1) from the first stage cylinder bore.

j. Position the shim (4), spacer (3), intake valve (2), gasket (1), and valve plate (15) into the first stage cylinder bore.

k. Position the preformed packing seal (11) in the groove in the head assembly (7)

l. Position the discharge valve spring (12), discharge valve (13) and discharge valve seat (14) on the head assembly (7) and secure the head assembly by using the screw (17), gasket (16), washer (10), and nut (9). Apply a torque to the nut until the hole in the screw is aligned with the hole in the nut. Position the cotter pin (18) into the aligned holes and bend the cotter pin over the nut and along the screw. The maximum permissible torque on the nut is .8 pound-feet.

m. Position the head assembly (7) on the valve plate (15) and orient the outlet port in the head assembly 120° to the left from the dead front point on the first stage cylinder and align the screw holes in the head assembly with the screw holes in cylinder.

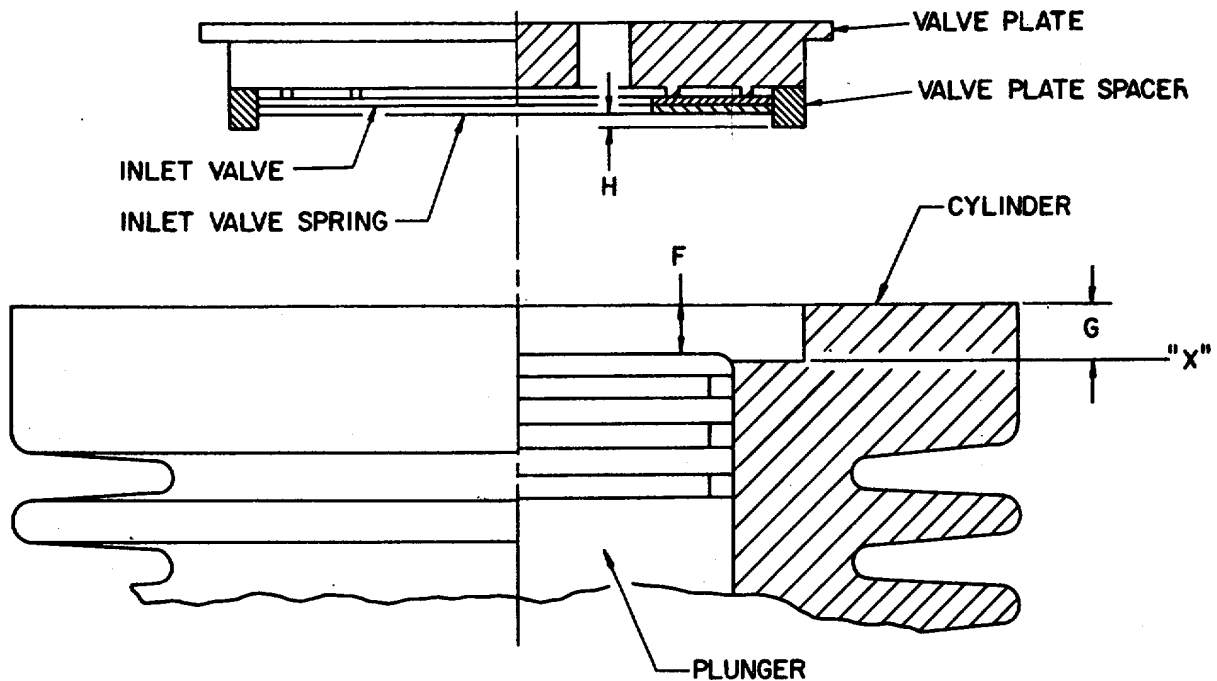

NOTE:
**MEASUREMENTS TAKEN WITH
 PLUNGER AT TOP DEAD CENTER.**

CALCULATIONS:
 $G - F = I$
 $H - I = J$
J = TOTAL HEAD CLEARANCE
 $J - 0.018 \pm .002 = K$
**K = THICKNESS OF SHIM
 (WITH OR WITHOUT SPACER)**

Figure 18. Second stage head clearance.

Secure the head assembly to the first stage cylinder with the six screws (5) and washers (6). Apply a torque of 30 to 35 pound-inches to the screws using the torque wrench and 9/64-inch socket wrench.

n. Position the preformed packing (23) in the groove on the cap (22).

o. Position the filter assembly (24), cap (22) and cap (21) on the head assembly (7) and secure with four screws (19) and washers (20). Apply a torque to the screws between 17 and 22 pound-inches.

p. Assemble the outlet elbow (8) to the outlet port of the head assembly (7).

Note

Final orientation of the elbow is not determined until assembly of the first stage intercooler.

45. Second Stage Assembly

a. Determine the thickness of shim (15, fig. 12) required to give a proper second stage head clearance between 0.016 and 0.020 inches as described in b through h below. Refer to figure 18.

b. Insert the second stage plunger subassembly (17, fig. 12) into the 2d stage cylinder bore of the crankcase (14, fig. 16); rotate the crankshaft (11, fig. 15), using a suitable size hexagonal bar stock, so that the plunger is at top dead center.

c. Using a depth micrometer, measure the distance from the flat surface of the second stage cylinder to the top of the second stage plunger subassembly (17, fig. 12). Record this value as the value "F."

d. Measure the distance from the flat surface of the second stage cylinder to the flat seating surface of the shim (15, fig. 12) in the second stage bore. Record this value as the value "C."

e. Position the inlet valve (11) on the inlet 29

valve seating surface of the valve plate (10). Position the valve spring (12) on the inlet valve. Position the spacer (13) on the valve plate. Measure the distance from the surface of the spacer to the surface of the spring. Record this value as the value "H."

f. Determine the total second stage head clearance by subtracting the value of "F" from the value of "G." Record this value as the value "I." Subtract the value "I" from the value "H" and record as the value "J." This value "J" is the total head clearance.

g. Select the proper value of shim (15) by subtracting $0.018 + .002$, which is the required second stage head clearance, from the value "J" and record this value as the value "K"; select enough of shim with or without the spacer (14) to equal the value "K". This selection of shim with or without the spacer will provide the proper head clearance for the second stage.

h. Remove the plunger subassembly (17) from the second stage cylinder bore.

i. Assemble the three plunger rings (16) to the plunger subassembly (17).

j. Position the plunger assembly (18) into the second stage cylinder bore using the second stage plunger insertion sleeve.

k. Position the selected thickness of shim (15), spacer (14), if required, and spacer (13), in the second stage cylinder bore.

Note

The leaded surfaces shall be exposed on both sides of the shim.

l. Position the inlet valve spring (12), inlet valve (11), and the valve plate (10) in the second stage cylinder bore.

m. Position the gasket (6) and the gasket (7) in place in the head assembly (5).

n. Position the discharge valve (9) on the discharge valve seat of the valve plate (10) and follow with the discharge valve spring (8).

o. Position the head assembly (5) on the valve plate (10) orienting the outlet port to the front of the compressor assembly. Align with the screw holes in the second stage cylinder. Secure the head assembly (5) the four screws (1) and washers (2). Apply a torque to screws between 60 to 65 pound-inches using a 3/16-inch socket wrench.

p. Assemble the elbow (4) to the inlet port and elbow (3) to the outlet port of second stage head assembly (5).

Note

Final positioning of the elbows will be determined during the assembly of the first and second stage intercoolers.

46. Third Stage Assembly

a. Determine the proper thickness of shim (2, fig. 11) required to give a proper 3d stage head clearance between 0.010 and 0.015 inches as described in b through i below; refer to figure 19.

b. Position the plunger and cylinder assembly (4, fig. 11) onto the third stage port in the crankcase (14, fig. 16); rotate the crankshaft (11, fig. 15), using a suitable size hexagonal bar stock, so that the plunger is at top dead center.

c. Using a depth micrometer, measure the distance from the top of the 3d stage cylinder to the top of the third stage plunger. Record this value as value "L."

d. Position the gasket (12, fig. 11) in the third stage cylinder bore and measure the distance from the top of the third stage cylinder to the top of the gasket. Record this value as value "M."

e. Position the inlet valve (6) and the inlet valve spring (5) on the valve plate (8). Measure the distance from the surface of the inlet valve spring to the outer surface of the valve plate and record this value as value "N."

f. Measure the distance from the surface of the inlet valve spring (5) to the inner surface of the valve plate (8) and record this value as value "O."

g. Determine the total third stage head clearance by subtracting the value "M" from the value "L" and record the value "N" from as value "P." Subtract the value "N" from the value "O" and record the remainder as value "Q." Add the value "P" and the value "Q" and record the sum as the value "R". The value "R" is equal to the total third stage head clearance.

h. Determine the proper thickness of the shim (2) by subtracting the required head clearance of 0.010 to 0.015 inches from the value "R" and record the remainder as value "S." The thickness of the shim with or without the spacer (3) must be equal to the value "S".

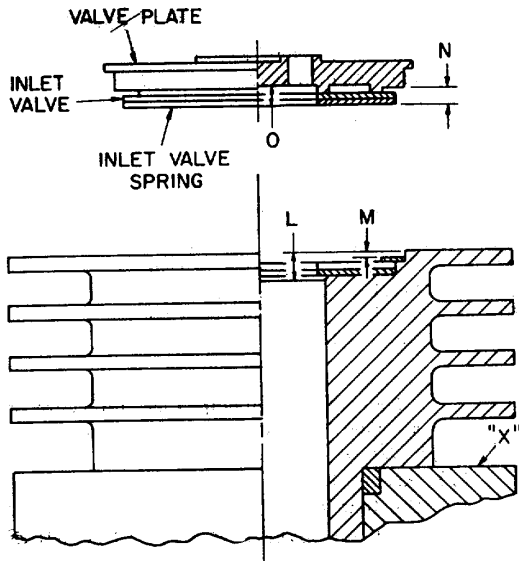

NOTE:
MEASUREMENTS TAKEN WITH PLUNGER
AT TOP DEAD CENTER.

CALCULATIONS:

L-M=P
O-N=Q
P+Q=R
R= TOTAL HEAD CLEARANCE
R-0.0125 ±.0025=S
S=THICKNESS OF SHIM
(WITH OR WITHOUT SPACER)

Figure 19. Third stage head clearance.

i. Remove the plunger and cylinder (4) from the crankcase (14, fig. 16).

j. Position the preformed packing (1, fig. 11) in the third stage port in the crankcase (14, fig. 16).

k. Position the proper thickness of shim (2, fig. 11) with or without the spacer (3) to give the proper third stage head clearance, on the lower side of the third stage plunger and cylinder assembly (4) and position the plunger and cylinder assembly in the third stage port in the crankcase (14, fig. 16).

l. Position the inlet valve spring (5, fig. 11), inlet valve (6), gasket (7) and valve plate (8) on the plunger and cylinder assembly (4).

m. Position the gaskets (11 and 12) in the grooves on the head assembly (14).

n. Center the discharge valve (9) and the discharge valve spring (10) on the valve plate (8) and then position the head assembly (14) on the valve plate so that the inlet port is oriented to the front of the compressor assembly and the screw holes in the crankcase (14, fig. 16), plunger and cylinder assembly (4, fig. 11)', and the head assembly are in alignment. Secure the third stage section with the four screws (16) and washers (15) and apply a torque to screws between 60 to 65 pound inches using the torque wrench and 9/64-inch socket wrench.

o. Assemble the second stage relief valve (17) to the inlet port and the elbow (13) to the discharge port of the head assembly (14).

Note

Final orientation of the elbow (13) and the second stage relief valve (17.) is determined during the assembly of the second stage intercooler anti the aftercooler.

p. Position the preformed packing (18) and the fourth stage plug (19) on the fourth stage port in the crankcase (14, fig. 16) and secure with the four screws (22, fig. 11) and washers (20). Apply a torque between 50 and 60 pound-inches to the screws using a 3/16-inch socket wrench. Secure the screws after assembly using a lockwire (21).

47. Testing

Prior to normal operation and use of the compressor group in the overall unit, various test runs of the compressor group must be accomplished. The type of test run performed on the compressor group is dependent upon the scope of replacement performed during overhaul of the compressor group. In the event that replacement of the crankcase, first stage piston, first stage piston rings, second stage plunger or second stage plunger rings is required, a four-hour special run is to be performed. If the third stage cylinder and plunger assembly is replaced in the compressor group the performance of an eight-hour special run is required. The replacement of any other pneumatic system parts require a one-hour minimum special run.

Caution

Performance of the special runs are accomplished when the compressor is complete with coolers, brackets, fan and fan guard and mounted on the test stand. The test stand is used to perform all special runs.

a. *Four-Hour Special Run.*

- (1) Assemble the compressor group to the test stand, fill the oil sump to the required level

with oil FSN 9150-753-4667, and check the operation of the compressor group for the required values indicated in table 1.

Table I. Four-Hour Run-In Procedure.

Start time	Speed (rpm)	Back pressure (psig)	Blowby (cfm)	Maximum oil consumption	Oil leakage	Change time
0	1500 - 2000	400 + 200	5	7 cc/hr	None	2:00
2:00	2500 ± 100	1000 ± 100	5	7 cc/hr	None	3:00
3:00	3600 ± 100	2000 ± 100	5	7 cc/hr	None	4:00

- (2) Connect the aftercooler to the water separator or a suitable reservoir whose capacity is 208 ± 3 cu. in. and determine maximum pump-up time from 0 to 2000 psig when operating at 3600 ± 100 rpm. The maximum pump-up time is five minutes and thirty seconds.

Note. This pump-up time procedure is accomplished after all special runs.

b. *Eight-Hour Special Run.*

- (1) Assemble the compressor group to the test stand, fill the oil sump to the required level using oil FSN 9150753-4667 and check the operation of the compressor group for the required values indicated in table II.

Table II. Eight-Hour Run-In Procedure

Start time	Speed (rpm)	Sack pressure (psig)	Blowby (cfm)	Maximum oil consumption	Oil leakage	Change time
0	1500 -2000	400 + 200	5	7 cc/hr	None	2:00
2:60	2500 ± 100	1000 ± 100	5	7 cc/hr	None	5:00
5:00	3600 ± 100	2000 ± 100	5	7 cc/hr	None	8:00

- (2) Check the pump-up time as indicated in the four-hour special run, (a (2) above).

test stand, fill the oil sump to the required level with oil FSN 9150-7534667, and check the operation of the compressor group for the required values indicated in table III.

c. *One-Hour Special Run.*

- (1) Assemble the compressor group to the

Table III. One-Hour Run-In Procedure

Start time	Speed (rpm)	Back pressure (psig)	Blowby (cfm)	Maximum oil consumption	Oil leakage	Chan-e time
0	1500 - 2000	400 + 200	5	7 cc/hr	None	1:00

- (2) Check the pump-up time as indicated in the four-hour special run (a (2) above).

washers (1). Apply a torque between 8 to 9 pound-feet to the four screws (2).

48. Installation (fig. 10)

- a. Position the compressor group on the gasoline engine and secure using the four bolts (2) and four

b. Replace the fan guard section (par. 25a) and intercooler and aftercooler section (par.).

Section VI. ENGINE GROUP

49. Description and Function

The engine group is a one-cylinder, four-stroke cycle, overhead valve, aircooled, gasoline fueled unit designed to develop $\frac{1}{2}$ hp at 3,600 rpm. Included with the gasoline engine are various accessory components required to facilitate operation of the unit. The splined, engine adapter is secured to the drive shaft of the gasoline engine and is used to drive the crankshaft of the compressor assembly. The tube assembly is secured to the frame assembly by a clamp and is attached to the shutoff cock and the filter and connector. The tube assembly is used to conduct the fuel from the fuel tank to the carburetor of the gasoline engine. Attached to the gasoline engine are four clip angles which are used to mount the gasoline engine to the frame assembly. At the rear of the gasoline engine is attached the pulley. The pulley is used with the rope starter to manually start the gasoline engine.

50. Maintenance

Fourth echelon maintenance personnel are authorized to replace the adapter, tube assembly, clamp, clip angles, pulley, and gasoline engine. For detail maintenance of the gasoline engine, refer to TM 5-2805-206-14.

a. Removal.

- (1) Perform the disassembly authorized in paragraph 16a.
- (2) Disconnect the aftercooler (6, fig. 9) from the water separator inlet elbow (12, fig. 3).
- (3) Unscrew the eight bolts (10, fig. 20), washers (9) and remove the engine group and compressor group from the lower frame (9, fig. 21).
- (4) Unscrew the four bolts (2, fig. 10) and washers (1, fig. 10) and remove the compressor group from the engine group (4, fig. 20).

b. Disassembly (fig. 20).

- (1) Unscrew the screw (3) and remove the adapter (2) from the gasoline engine (4).
- (2) Unscrew the screws on the gasoline engine (4) holding the pulley (1) and replace the attaching screws on the gasoline engine (4).

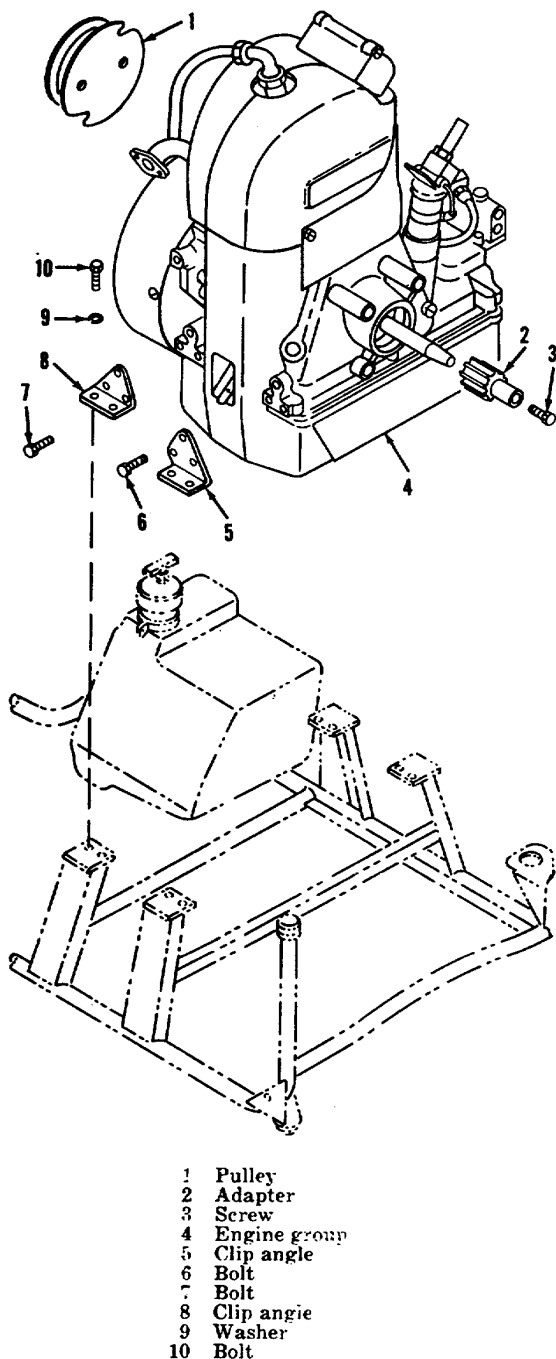

Figure 20. Engine group, partial exploded view.

- (3) Unscrew the six bolts (6) and remove the two clip angles (5) from the gasoline engine (4).

- (4) Unscrew the six bolts (7) and remove the two clip angles (8) from the gasoline engine (4).

e. Cleaning and Inspection.

- (1) Clean all metallic parts in ultrasonic cleaner.
- (2) Inspect all parts for clogging, dents, scratches, or any other damage. Replace damaged or defective components.

d. Lubrication.

- (1) Apply antiseize compound per JANA-6169 to threaded components on the fuel system.
- (2) Apply oil (OE-30) to the threaded areas of the aftercooler (6, fig. 9).

e. Assembly (fig.20).

- (1) Position the two clip angles (8) on the gasoline engine (4) and secure in place using the six bolts (7). Apply a torque of 5 to 7 pound-feet to the bolts (7).
- (2) Position the two clip angles (5) on the gasoline engine (4) and secure in place using the six bolts (6). Apply a torque of 5 to 7 pound-feet to the bolts (6).
- (3) Remove the two screws of the gasoline engine (4) used to hold the pulley (1).

Assemble the pulley to the gasoline engine. (4) with the removed screws and tighten the screws securely.

- (4) Position the adapter (2) to the drive shaft of the gasoline engine (4) and secure using the screw (3). Apply a torque of 20 pound-feet using the torque adapter.

f. Installation.

- (1) Position the compressor group to the engine group (4, fig. 20) and secure in place with the four bolts (2, fig. 10) and the four washers (1). Apply a torque of 7 -to 8 pound-feet to bolts.
- (2) Position the engine group and compressor group on the lower frame engine mounting surfaces and secure the assembly to the lower frame (9, fig. 21) using the eight bolts (10, fig. 20) and washers (9). Apply a torque -of 5 to 7 pound-feet to the bolts (10).
- (3) Connect the aftercooler (6, fig. 9) to the water separator inlet elbow (12, fig. 3) and apply a torque of between 3 to 5 pound-feet to the aftercooler nut.
- (4) Perform the assembly as indicated in paragraph 12e (5).

Section VII. FRAME-FUEL TANK GROUP

51. Description and Function

The fuel tank is a gasoline storage tank mounted on the frame assembly. An identification nameplate is assembled to the fuel tank. The frame assembly consists of a tubular upper frame and a rubber-mounted, tubular lower frame that are joined together by coupling nuts. The frame assembly is used as the mounting base for the entire unit.

52. Maintenance

Fourth echelon maintenance is authorized to replace the identification nameplate, fuel tank assembly, upper frame; lower frame, rubber mounts, and the attaching hardware.

a. Removal (fig. 21).

- (1) Unscrew the coupling nuts on the upper frame (1) and remove the upper frame from the lower frame (9).

- (2) Remove the fuel tank accessories as indicated in paragraph 18a.
- (3) Unscrew the two bolts (14) and washers (15) and remove the tank assembly (8) from the lower frame (9).

b. Disassembly (fig. 21).

- (1) Remove the instruction plate (3) from the upper frame (1) by disassembling the four screws (2) and four lock nuts (5).
- (2) Remove the four cushion clamps (4) from the upper frame (1).
- (3) Unscrew the four screws (7) and remove the nameplate (6) from the tank assembly (8).
- (4) Unscrew the four nuts (10), the four washers (11), the four screws (13), and the four rubber mounts (12) from the lower frame (9).

c. *Cleaning and Inspection* (fig. 21).

- (1) Clean all metallic parts with cleaner P-S-661.
- (2) Inspect all components for bends, breaks, scratches, damaged threads, and other defects.
- (3) Replace all rubber mounts (12).

d. *Assembly* (fig. 21).

- (1) Position the four rubber mounts (12) on the lower frame (9) and secure to the frame using the four screws (13), washers (11), and nuts (10).
- (2) Position the nameplate (6) on the tank assembly (8) and secure using the four screws (7).

- (3) Position the four cushion clamps (4) on the upper frame (1).
- (4) Attach the instruction plate (3) to the four cushion clamps (4) using the four screws (2) and locknuts (5).

e. *Installation* (fig. 21).

- (1) Position the tank assembly (8) to the mounting bracket on the lower frame (9) and secure using the two bolts (14) and washers (15). Apply torque to screws 5 to 7 pound-feet.
- (2) Replace the fuel tank accessories (par. 18d).
- (3) Position the upper frame (1) on the lower frame (9) and secure the coupling nuts on the upper frame.

Section VIII. PERIODIC SURVEILLANCE TEST

53. General

Fourth echelon maintenance personnel will recall and test water separator groups from the field at 12-month intervals.

54. Test Procedure

Test the water separator, without the relief valve. Refer to figure 3.

a. Cap the drain port and plug the outlet port and relief valve port using suitable high pressure caps and plugs.

Warning

Be extremely careful when working with pneumatic equipment to prevent injury to personnel and damage to property resulting from careless handling or possible equipment failure. Perform all testing in an assigned area, cleared of all unauthorized personnel. Make certain all equipment is properly cleaned and secured. Clamp all pneumatic equipment being tested firmly in a vise or other holding, suitable testing fixture. Do not attempt to adjust or disassemble equipment under pressure. Use a heavy metal shield, equipped with suitable safety glass windows to protect personnel whenever proof pressure testing.

b. Connect the inlet elbow (12) to a regulated, high pressure, hydrostatic line provided with a suitable pressure gage and atmospheric vent line.

c. Apply 3000 psi hydrostatic pressure for one minute to the water separator. Vent the hydrostatic pressure to atmosphere and inspect for failure or deformation. Disconnect from hydrostatic pressure line.

d. Connect to a high pressure pneumatic line and apply 2000 psi pneumatic pressure for two minutes and submerge in clean water. No leakage is permitted in the two-minute test.

Note. The maximum allowable leakage permitted for the water separator is 3 cc per hour.

e. Vent the pneumatic pressure to atmosphere and disconnect the water separator from the high pressure, pneumatic line. Remove the test plugs and caps. Blow dry with clean dry air.

f. Metal stamp nameplate on water separator with month and year of proof testing. Discard water separator when due for third proof testing.

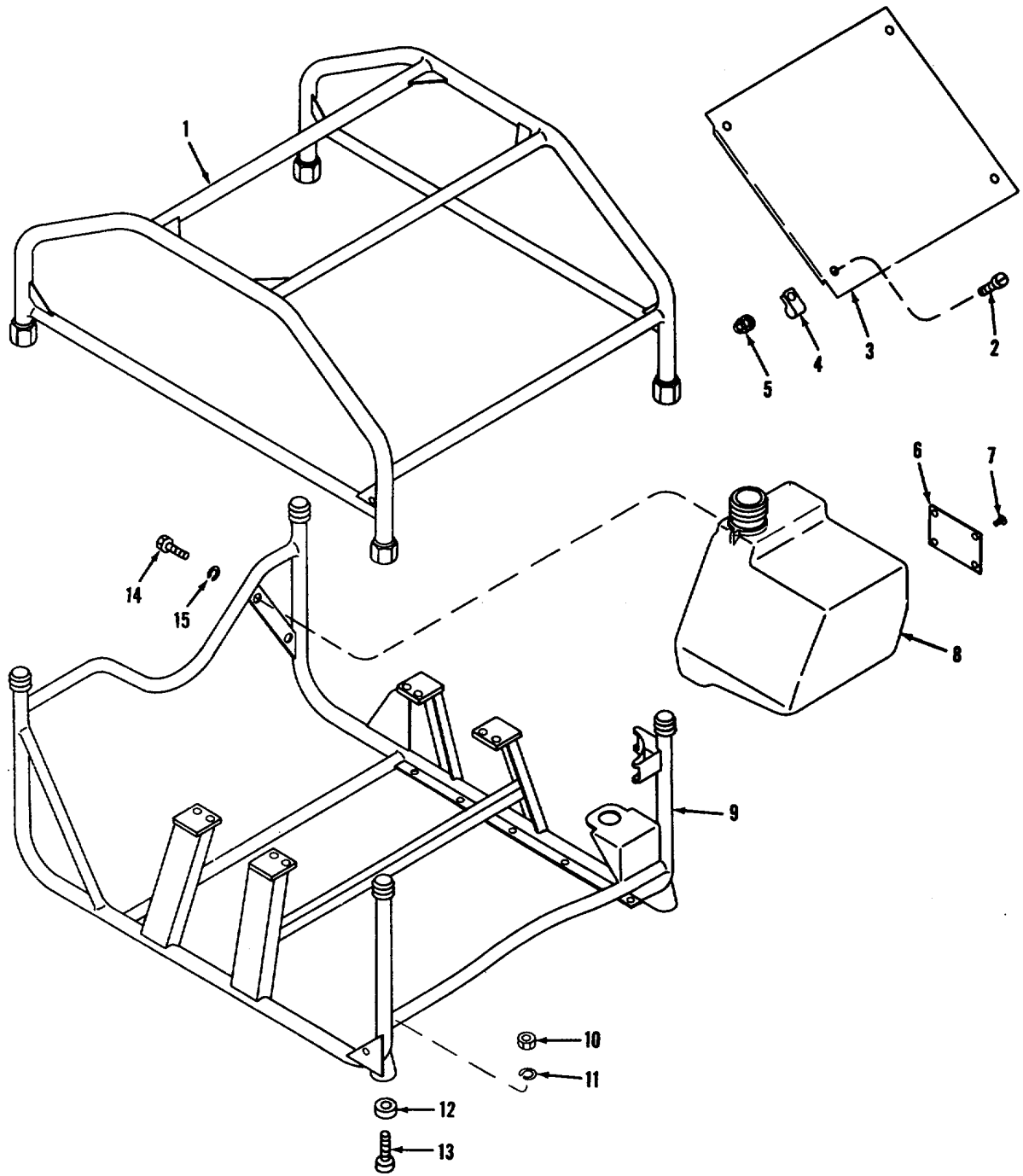

- | | | |
|---------------------|-----------------|-----------|
| 1 Upper frame | 6 Nameplate | 11 Washer |
| 2 Screw | 7 Screw | 12 Mount |
| 3 Instruction plate | 8 Tank assembly | 13 Screw |
| 4 Cushion clamp | 9 Lower frame | 14 Bolt |
| 5 Lock nut | 10 Nut | 15 Washer |

Figure 21. Frame and fuel tank section, exploded view.

CHAPTER 4

DEPOT MAINTENANCE INSTRUCTIONS - FIFTH ECHELON

55. Engine Group

Overhaul and rebuild of the engine group will be as indicated in TM 5-2805-206-14.

56. Compressor Group

Overhaul and rebuild of the compressor group will be in accordance with local depot procedures.

APPENDIX I

REFERENCES

TM S-1040-210-12	Operator, Organizational Maintenance Manual, Compressor Reciprocating, Power Driven, Flamethrower, 3 ½ CFM, AN-M4.
TM 3-1040-210-20P	Organizational Maintenance Repair Parts and Special Tools, List, Compressor, Reciprocating, Power Driven Flamethrower, 3 ½ CFM, AN-M4.
TM 3-1040-210-35P	Field and Depot Maintenance Repair Parts and Special Tools List, Compressor, Reciprocating, Power Driven, Flamethrower, 3 ½ CFM, AN-M4.
TM 5-280o206-14	Operator, Organizational and Field Maintenance Manual Engine, Gasoline (Military Standard Models) (Model 1A08-1) 1 ½ hp, FSN 2805-601-5181, (Model 1A08-2) 1 ½ hp, FSN 2805-714-8552, (Model 2A016-1) 3 hp, FSN 2805-601-5127, (Model 2A016-2) 3 hp, FSN 2805-714-8553.
TM 5-2805-206-14P	Operator, Organizational and Field Maintenance Repair Parts and Special Tools List Engine, Gasoline (Military Standard Models) (Model 1A081) 1 ½ hp, FSN 2805-601-5181, (Model 1A08-2) 1 ½ hp, FSN 3805-714-8552, (Model 2A016-1) 3 hp, FSN 2805-601-5127, (Model 2A0162) 3 hp, FSN 2805-714-8553.
TM 9-213	Painting Instructions for Field Use.

By Order of the Secretary of the Army:

Official:

EARLE G. WHEELER,
General, United States Army,
Chief of Staff

J. C. LAMBERT,
Major General, United States Army,
The Adjutant General.

Distribution:

Active Army.

CNGB (1)	OS Maj Comd (5)	Trans Tml Comd (1)
USA Maint Bd (2)	Armies (5)	Army Tml (1)
USACBRCDA (2)	Corps (3)	Instl (2)
USAADCDA (2)	USA Corps (1)	Arsenals (3)
USAARMCDA (2)	Div (3)	Cml Proc Dist (3)
USAARTYCDA (2)	Svc Colleges (10)	PG (5)
USAAVNCDA (2)	Br Svc Sch (10) except	Units org under fol TOE:
USAICDA (2)	USACMLCSCH (50)	3-7 (1)
USASWCDA (2)	USMA (10)	3-32 (1)
USAARMC (2)	GENDEP (OS) (5)	3-36 (1)
USAAMC (4)	Cml Sec, GENDEP (OS) (5)	3-47 (2)
USA Engr Cen (2)	Cml Dep (OS) (5)	3-67 (2)
USAIC (2)	Army Dep (5)	3-117 (2)
USAMC (5)	USAMUCOM (5)	3-147 (1)
USCONARC (10)	USA CBR Engr Gp (15)	3-500 (AA-AC) (1)
ARADCOM (5)	USAOSA (2)	
ARADCOM Rgn (5)	POE (1)	

NG: State AG (3).

USAR: Units-same as Active Army except allowance is one copy for each unit.

For explanation of abbreviations used, see AR 320-50.

AGO 5548A

RECOMMENDED CHANGES TO EQUIPMENT TECHNICAL PUBLICATIONS



THEN... JOT DOWN THE DOPE ABOUT IT ON THIS FORM, CAREFULLY TEAR IT OUT, FOLD IT AND DROP IT IN THE MAIL!

SOMETHING WRONG WITH THIS PUBLICATION?

FROM: (PRINT YOUR UNIT'S COMPLETE ADDRESS)

DATE SENT

PUBLICATION NUMBER

PUBLICATION DATE

PUBLICATION TITLE

BE EXACT... PIN-POINT WHERE IT IS

IN THIS SPACE TELL WHAT IS WRONG AND WHAT SHOULD BE DONE ABOUT IT:

PAGE NO.	PARA-GRAPH	FIGURE NO.	TABLE NO.

TEAR ALONG PERFORATED LINE

PRINTED NAME, GRADE OR TITLE, AND TELEPHONE NUMBER

SIGN HERE:

DA FORM 2028-2 JUL 79

PREVIOUS EDITIONS ARE OBSOLETE.

P.S.—IF YOUR OUTFIT WANTS TO KNOW ABOUT YOUR RECOMMENDATION MAKE A CARBON COPY OF THIS AND GIVE IT TO YOUR HEADQUARTERS.

